



Forno Bravo

The World's Finest Pizza Ovens

Professionale Series

Commercial Pizza Ovens for Restaurants, Cafes and Bistros

The Professionale Series is designed for smaller restaurants, pizzerias, cafes and bistros, as well as larger restaurants, looking for a wood or gas fired pizza oven to complement other cooking equipment. While the Professionale ovens are small and cost-effective, they are built using the same ultra-premium refractory and insulating materials as our Modena2G ovens—and they bake perfect Pizza Napoletana.

The ovens feature an interlocking, 3" oven dome, 18"X18"x2 1/2" compressed/kiln-fired firebrick cooking floor tiles and an integral vent. The ovens are available in two sizes, 44"x54" and 48"x 59". With 4-6" of ceramic dome and floor insulation, the Professionale ovens are efficient with wood fuel, and maintain both high temperature for non-stop high temperature baking.

The oven can be vented with a Direct Connect UL103 chimney system or Grease Duct vent, or with a Type 1 hood.

The Professionale Series ovens are available in two configurations, both either wood-fired, or gas, with gas/wood combo:

- The Professionale-FA, a fully assembled and fully insulated oven with a metal stand and red metal surround;
- The Professionale OK, an oven kit that includes the oven dome, vent, floor, door and thermometer, plus all of the insulation and high temp mortar.

The Forno Bravo Professionale ovens are UL737, UL2162, ANSI/NSF-4 and ANSIZ83a Certified.

Specification Sheet



The Professionale—perfect for restaurants and catering.



The Professionale Series

	Cooking Surface (in)	Area (m2)	Heat up (min)	Pizzas (10")
Professionale110	44" x 54"	.95	60	4-5
Professionale120	48" x 59"	1.25	75	5-6



744 Neeson Road
Marina, CA 93933
(800) 407-5119

info@fornobravo.com
www.fornobravo.com



Forno Bravo

The World's Finest Pizza Ovens

Forno Bravo Gas Burner System

The Forno Bravo Gas with Gas/Wood Combo option combines all of the advantages of traditional wood-fired baking, with the convenience of gas. The Forno Bravo burner system uses an electronically controlled, multi-line atmospheric burner, designed specifically for firing Italian-style dome pizza ovens.

Unlike other pizza oven burner systems, that require fans and extra burner elements such as infrared panels—and still don't maintain proper temperature, the Forno Bravo burner maintains high, even cooking temperature, just like wood.

Oven temperature is controlled electronically, giving the chef easy control over cooking temperatures. The burner works in two modes: a low flame, which is used for maintaining the oven temperature, and a high flame used for quickly bringing the oven to cooking temperature, and for dealing with peak cooking periods. This dual-mode operation delivers economy of operation, combined with high throughput performance and cooking.

The Forno Bravo burner works on an atmospheric burner principle, where combustion takes place just as it does with wood. There is a natural draw of air through the oven opening, and the flame created by the burner is widely diffused and very bright. This natural combustion delivers uniform cooking, high-performance "wood-like" flavors, and low maintenance costs compared with fan-assisted burners.

The burner itself does not protrude inside the oven, as it is installed inside the oven floor. The advantage of this design is significant. Unlike other burners, where the flame diffusers need to be replaced periodically, the Forno Bravo burner head does not become overheated.

Specification Sheet



A silent, diffused cone of flame works just like wood.



The Forno Bravo burner; installed under the oven floor.



Professionale Oven Kits: At-a-Glance

	Professionale110 OK	Professionale120 OK
Cooking Floor	44"W x 54"D	48"W x 59"D
External Dimensions	50"W x 57"D x 21.5"H	54"W x 62"D x 21.5"H
Oven Opening	18"W x 12.5"H	18"W x 12.5"H
Vent Landing	24"W x 10"D	24"W x 11"D
Dome Height	16.5"	16.5"
Monoblock Oven Opening and Vent	✓	✓
Sealing Door Jamb	✓	✓
Vent Opening Diameter	8"	8"
Ventilation Type	UL103, Type 1 Hood or Grease Duct	UL103, Type 1 Hood or Grease Duct
Commercial Grade, Kiln-Fired Cooking Floor	2.5"	2.5"
Ceramic Blanket Insulation (side/top)	4"/6"	4"/6"
Floor Ceramic Board Insulation	4"	4"
High Temp, Waterproof Mortar	✓	✓
Hinged, Insulated Door with Thermometer	✓	✓
Dome Pieces	7	7
Weight	1,850 lb.	2,050 lb.



Forno Bravo

The World's Finest Pizza Ovens

Specification Sheet

Professionale Oven Packages

	Modular Oven Kit (OK)	Fully Assembled (FA)
Oven Dome, Vent and Floor	✓	✓
Door and Thermometer	✓	✓
Complete Dome Ceramic Insulation (4"-6")	✓	✓
Complete Floor Ceramic Insulation (4")	✓	✓
Refractory Mortar	✓	✓
Decorative Brick Arch	Optional.	✓
Metal Tray, Stand & Surround	Optional.	✓
Fully Assembled (set it, connect it and light it)		✓
Modular (carry the pieces through a doorway)	✓	



Forno Bravo

The World's Finest Pizza Ovens

Specification Sheet

Professionale Ovens vs. The Other Guys

	Forno Bravo	The Other Guys
3" Commercial-Grade, High-Density Dome	✓	Some other ovens use less expensive materials and a lower quality dome casting process—that means less heat retention and less durability.
2 1/2" Commercial-Grade, Kiln-Fired Cooking Floor	✓	Some ovens feature cast/air-dried floors, which are can crack, and wear out more quickly than pressed and fired firebrick tiles. Other ovens have a very thin cooking floor, which cannot retain enough heat for high throughput baking.
Perfect Dome Height and Oven Opening Proportions	✓	Watch out for ovens with a very high dome and a large oven opening. These ovens are not suited to baking true Pizza Napoletana.
100% Ceramic Dome Insulation	✓	Some producers use vermiculite or rock wool, which are bulky and less efficient. Other oven kits do not include insulation. It is an expensive add-on.
100% Ceramic Floor Insulation	✓	Many ovens use less efficient vermiculite and have trouble holding heat for high throughput baking. Other oven kits do include insulation, which is an expensive add-on.
Gas with Gas/Wood Combo Option	✓	Some producers do not offer gas versions, and others do not offer gas/wood combo.
Gas Burner Works Just Like Wood	✓	Many oven burners are not capable of fully firing the oven and require expensive add-on burners—such as an infrared burner under the oven floor.
UL737, UL2162, NSF-4, ANSI-Z83a	✓	Make sure the oven you choose is Listed to each standard. They are all important for getting your permits.
Price (you'll be pleasantly surprised)	\$	\$\$\$\$



Forno Bravo

The World's Finest Pizza Ovens

Specification Sheet

Professionaale110-OK Dimensions

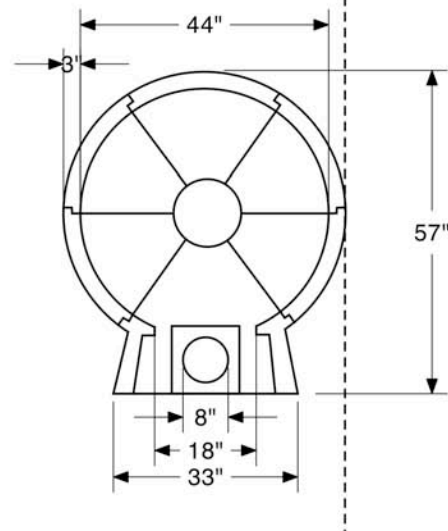
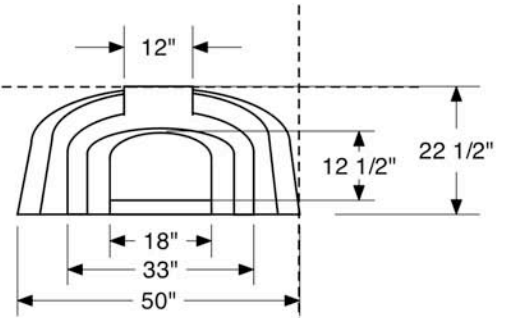
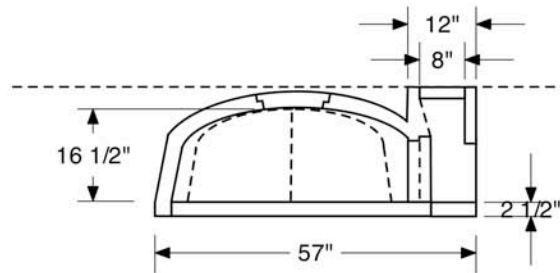

Forno Bravo

Professionaale110-OK Oven Kit

v1.1 03/11
 © Forno Bravo, LLC 2011
 744 Neeson Road
 Marina, CA 93933
 (800) 407-5119
 www.fomobravo.com

Clearances
 1" on sides, 14" on top
 after insulation.
Fuel
 Wood-only, or gas with gas/
 wood combo.

Ventilation
 Direct Connect using a UL103
 chimney or grease duct vent; or
 Type 1 Hood.Vent optional.
Brick Arch
 Optional.



Tested and compliant with UL737,
 UL2162, ANSI/NSF-4 and ANSI-Z83a



Forno Bravo

The World's Finest Pizza Ovens

Specification Sheet

Professionaale120-OK Dimensions

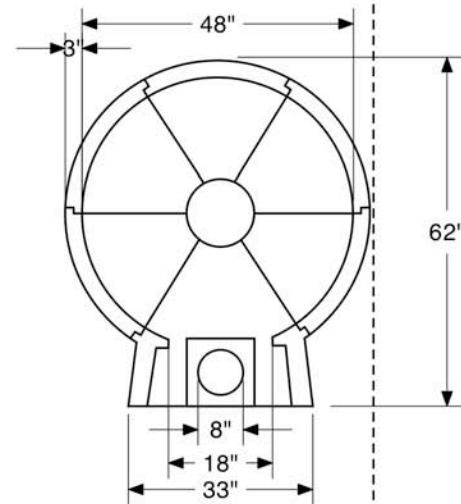
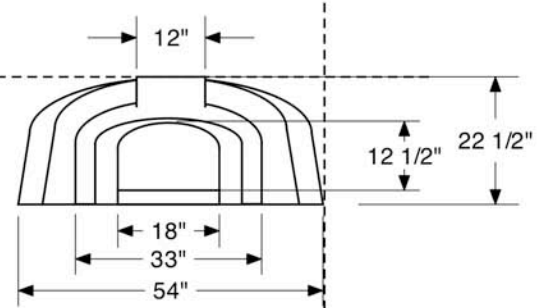
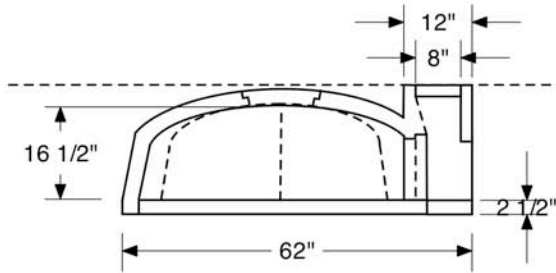

Forno Bravo

Professionaale120-OK Oven Kit

v1.1 03/11
 © Forno Bravo, LLC 2011
 744 Neeson Road
 Marina, CA 93933
 (800) 407-5119
 www.fomobravo.com

Clearances
 1" on sides, 14" on top
 after insulation.
Fuel
 Wood-only, or gas with gas/
 wood combo.

Ventilation
 Direct Connect using a UL103
 chimney or grease duct vent; or
 Type 1 Hood.Vent optional.
Brick Arch
 Optional.



Tested and compliant with UL737,
 UL2162, ANSI/NSF-4 and ANSI-Z83a



Forno Bravo

The World's Finest Pizza Ovens

Specification Sheet

Professionale110-FA Dimensions

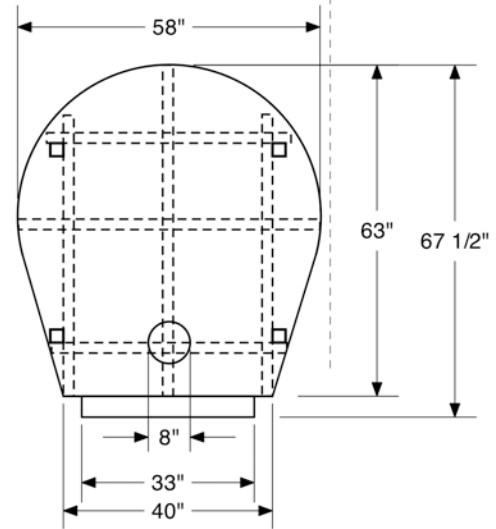
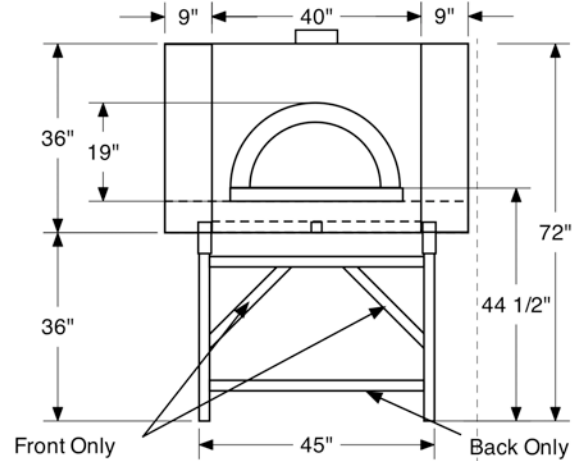
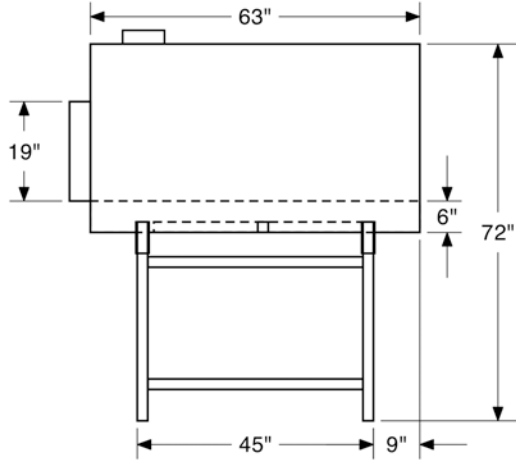

Forno Bravo

Professionale110-FA

v1.1 03/11
 © Forno Bravo, LLC 2011
 744 Neeson Road
 Marina, CA 93933
 (800) 407-5119
 www.fomobravo.com

Clearances

1" on sides, 14" on top.

Fuel

Wood-only, or gas with gas/wood combo

Ventilation

Direct Connect using a UL103 chimney or grease duct vent; or Type 1 Hood.



Tested and compliant with UL737, UL2162, ANSI/NSF-4 and ANSI-Z83a



Forno Bravo

The World's Finest Pizza Ovens

Specification Sheet

Professionale120-FA Dimensions

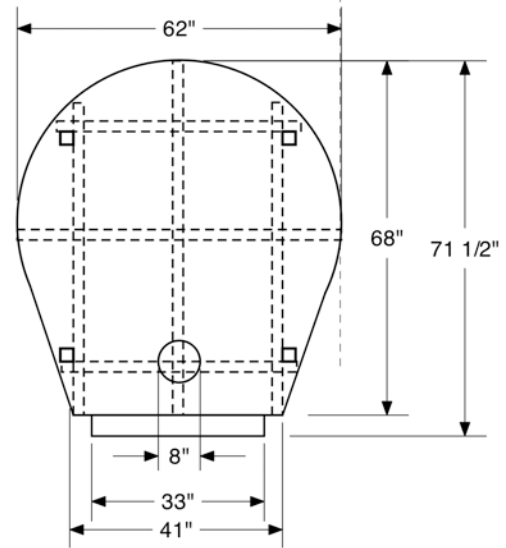
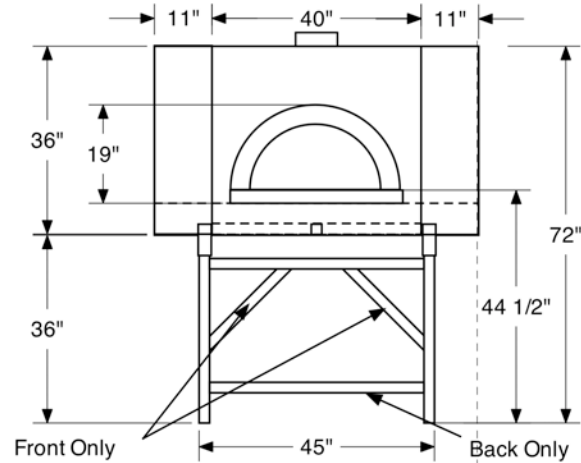
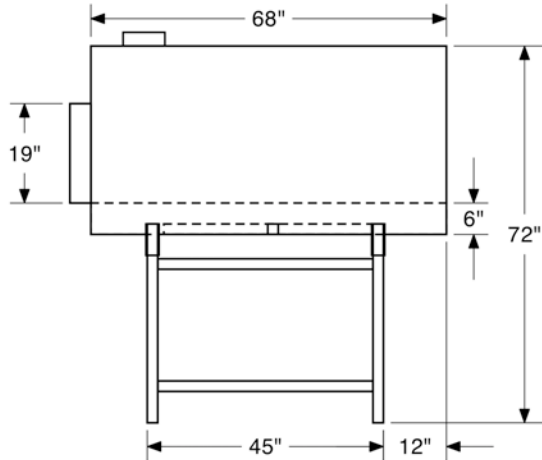

Forno Bravo

Professionale120-FA

v1.1 03/11
 © Forno Bravo, LLC 2011
 744 Neeson Road
 Marina, CA 93933
 (800) 407-5119
 www.fomobravo.com

Clearances

1" on sides, 14" on top.

Fuel

Wood-only, or gas with gas/wood combo

Ventilation

Direct Connect using a UL103 chimney or grease duct vent; or Type 1 Hood.



Tested and compliant with UL737, UL2162, ANSI/NSF-4 and ANSI-Z83a