

Front View

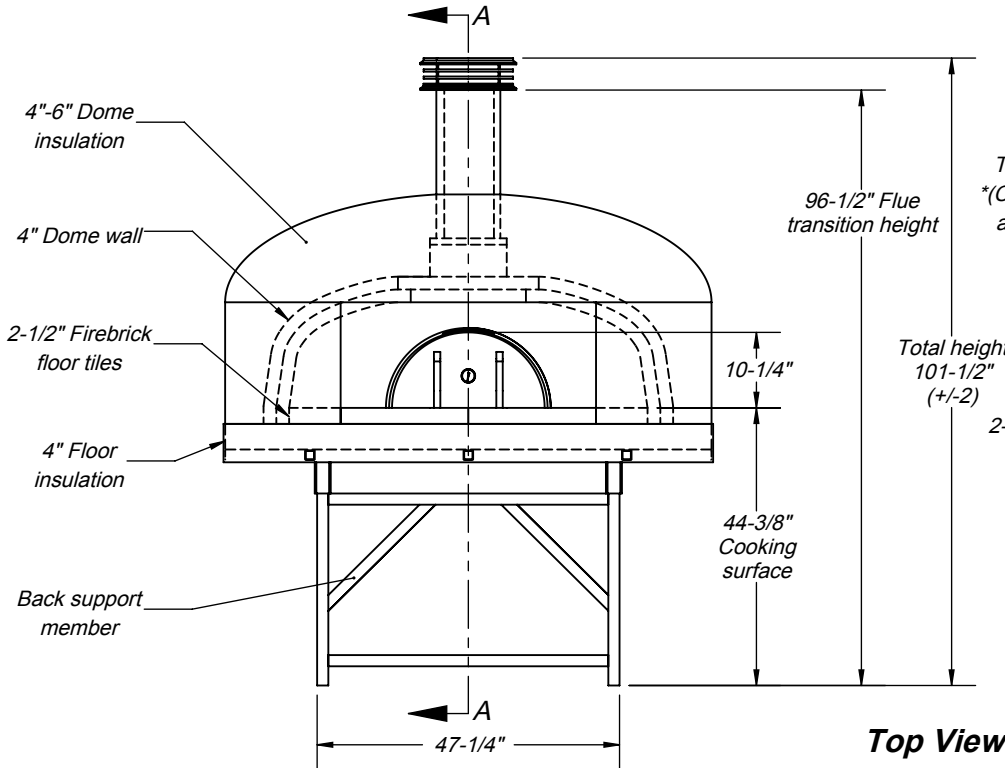

Side Elevation

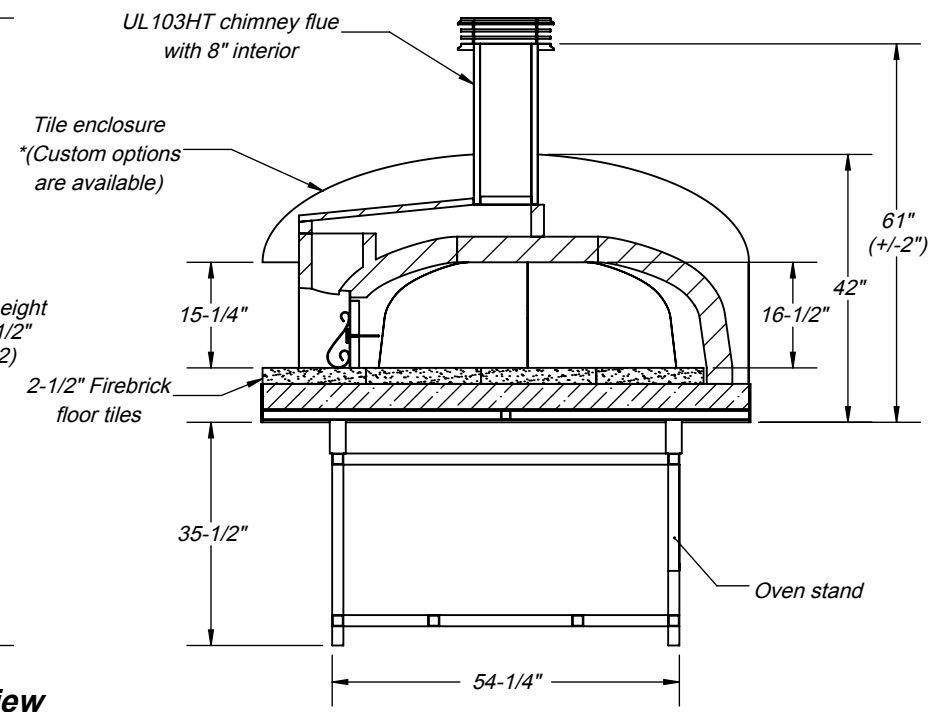

Top View

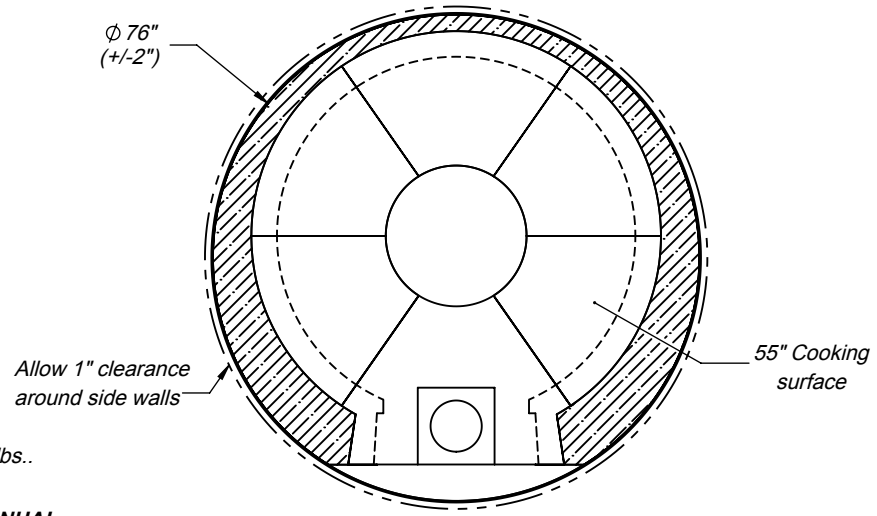

Clearance to combustibles:

- Allow 1" clearance all the way around side walls;
- 14" clearance above completed dome assembly;
- 30" Side clearance from door opening;
- 36" clearance from front landing;
- Non combustible metal hearth;

Specifications:

- Wood fuel;
- Available with or without the stand;
- Check local codes for venting requirements.
- Product UL listed for UL 103HT direct vent, Grease Duct or Type 1 Hood;
- Crate ships 81"W x 83"D x 86"H, Oven weight: 5614 lbs..

WARNING:

READ ALL INSTRUCTIONS IN INSTALLATION MANUAL BEFORE INSTALLING AND USING APPLIANCE. FAILURE TO FOLLOW INSTRUCTIONS MAY RESULT IN PROPERTY DAMAGE, BODILY INJURY OR EVEN DEATH.

For more information: www.fornobravo.com
https://www.fornobravo.com/PDF/commercial_install.pdf

Made in the U.S.A. Commercial Wood Fired Pizza Oven



Napoli 140W
 Wood Fired Pizza Oven w/ Stand

Architect Drawings SKU: FN140W-SS

Revision 01/23/17 Sheet: 1 of 4



Front View

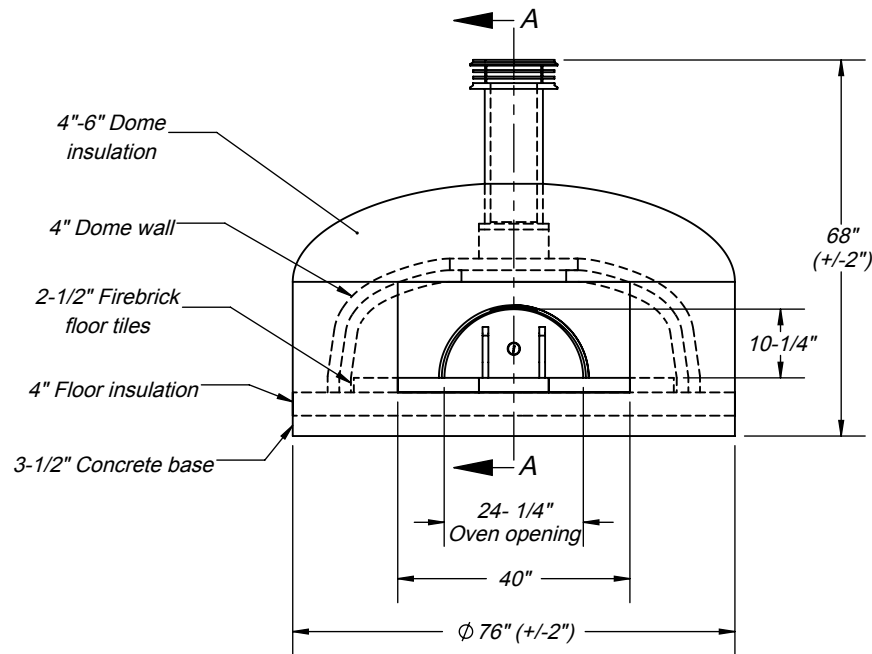

Side Elevation

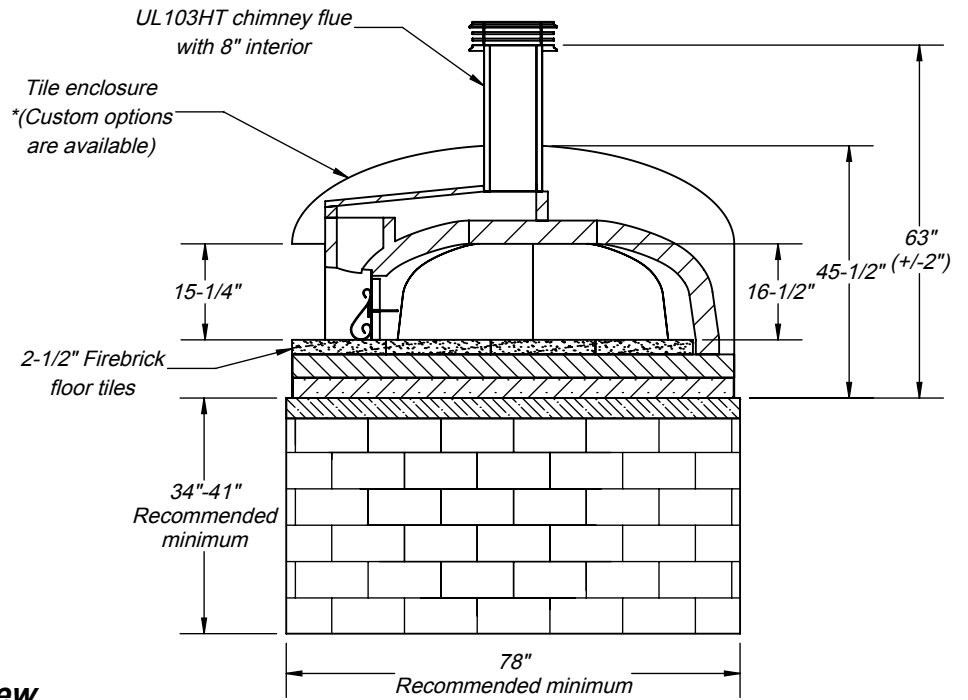

Top View

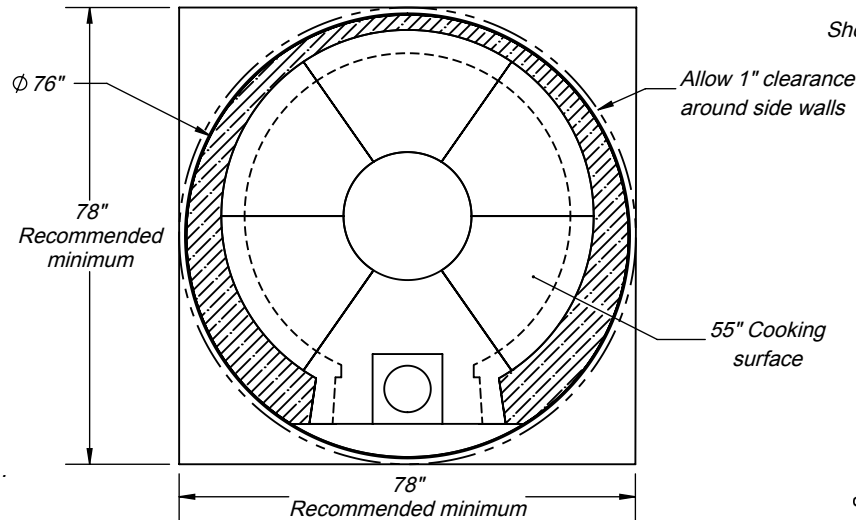

Clearance to combustibles:

- Allow 1" clearance all the way around side walls;
- 14" clearance above completed dome assembly;
- 30" Side clearance from door opening;
- 36" clearance from front landing;
- Non combustible metal hearth;

Specifications:

- Wood fuel;
- Available with or without the stand;
- Check local codes for venting requirements.
- Product UL listed for UL 103HT direct vent, Grease Duct or Type 1 Hood;
- Crate ships 81"W x 83"D x 66"H, Oven weight: 7054 lbs..

WARNING:

READ ALL INSTRUCTIONS IN INSTALLATION MANUAL BEFORE INSTALLING AND USING APPLIANCE. FAILURE TO FOLLOW INSTRUCTIONS MAY RESULT IN PROPERTY DAMAGE, BODILY INJURY OR EVEN DEATH.

SECTION A-A
Shown with non combustible concrete hearth

Made in the U.S.A. Commercial Wood Fired Pizza Oven



Napoli 140W
Concrete Masonry Unit (CMU)
Architect Drawings SKU: FN140W-NS



Revision 01/23/17 Sheet: 2 of 4

For more information: www.fornobravo.com
https://www.fornobravo.com/PDF/commercial_install.pdf

ISO View

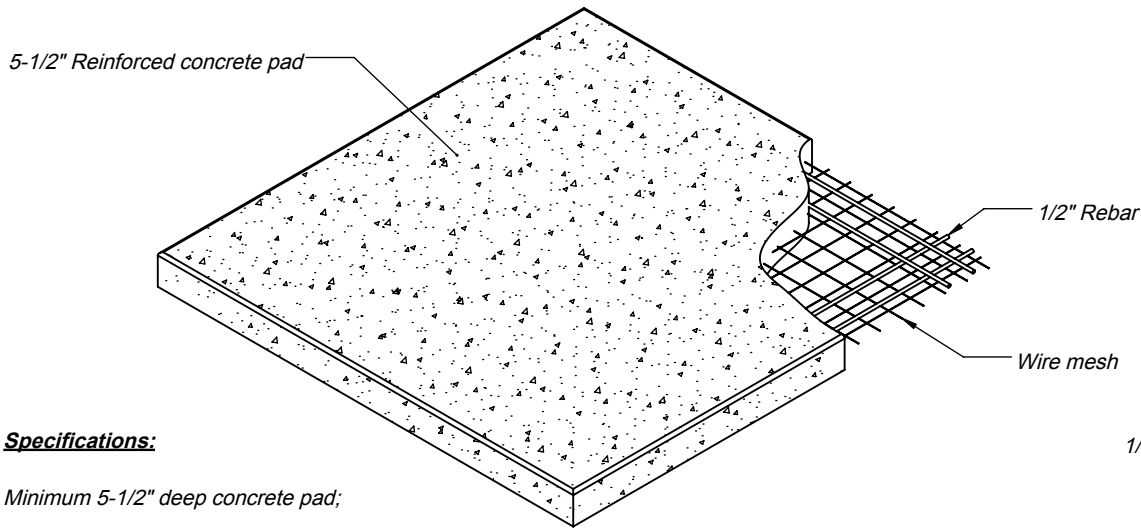

Top View

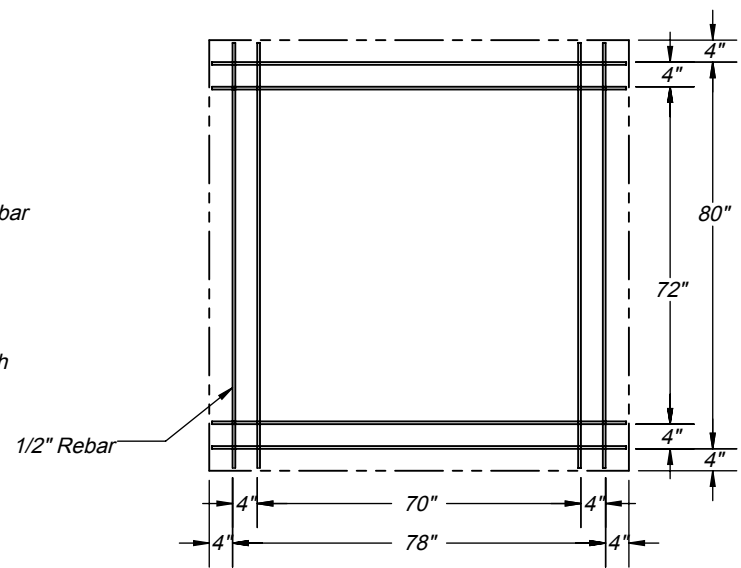

**Napoli 140W
oven stand footprint**

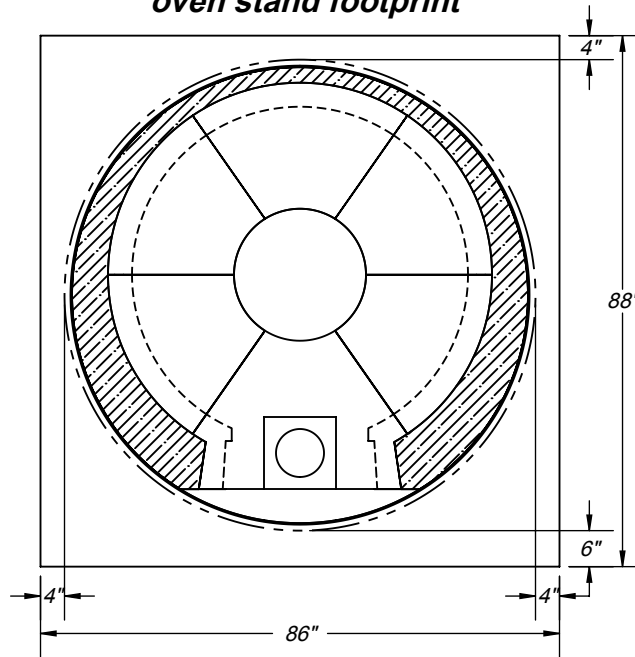

Side Elevation

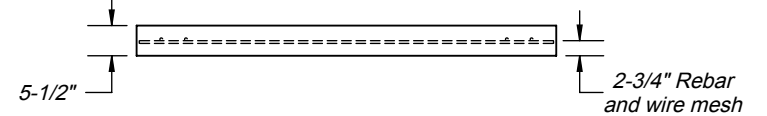

Specifications:

Minimum 5-1/2" deep concrete pad;

Reinforced with 1/2" rebar and wire mesh. * wire mesh is not shown in some views for print clarity;

Cut rebar and wire mesh short to conceal inside concrete pad;

*CMU stand requires a minimum cement foundation pad of 86"W x 88"D

Slab dimensions:

Minimum 8" wider than oven stand and hearth;

Minimum 10" deeper than oven stand and hearth;

Finished slab should be 2" to 3" above ground level;

Refer to local building codes for recommendations regarding soil compaction, frost line and other considerations. Depending on local conditions, you may have to excavate down 18" or more of topsoil to reach stable substrate.

WARNING:

READ ALL INSTRUCTIONS IN INSTALLATION MANUAL BEFORE INSTALLING AND USING APPLIANCE. FAILURE TO FOLLOW INSTRUCTIONS MAY RESULT IN PROPERTY DAMAGE, BODILY INJURY OR EVEN DEATH.

For more information: www.fornobravo.com
https://www.fornobravo.com/PDF/commercial_install.pdf

Made in the U.S.A. Commercial Wood Fired Pizza Oven



Napoli 140W
 Wood Fired Pizza Oven Pad
 Architect Drawings



Revision 01/23/17

Sheet 3 of 4

ISO View

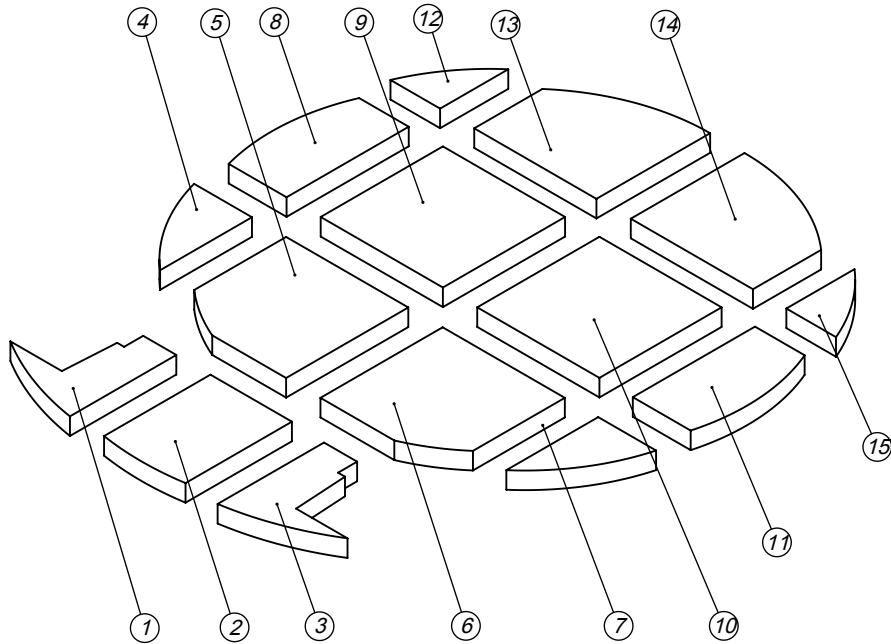

When ordering replacement tiles, reference tile number, pizza oven model and purchase date.

Top View

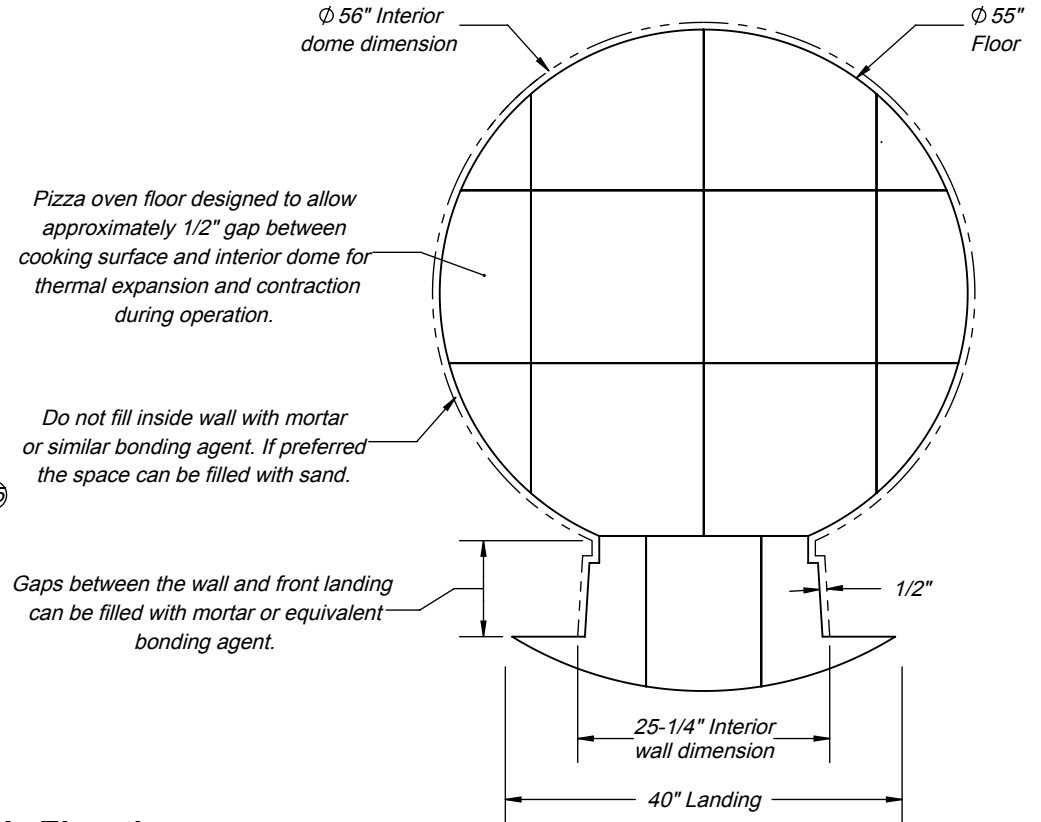

Side Elevation

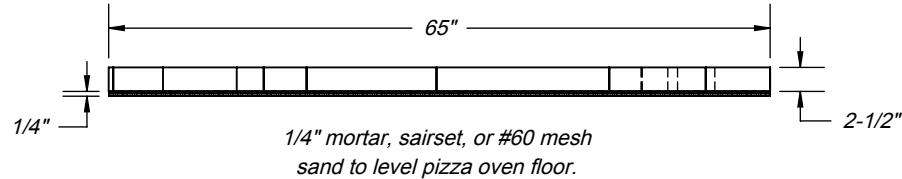

Specifications:

Pizza oven floor is NSF-4 rated with 2-1/2" thick surface.

Use 1/4" mortar, sairset ,or #60 mesh sand to level the floor.

No more than 3/8" filler around landing or door may not fit.

WARNING:
READ ALL INSTRUCTIONS IN INSTALLATION MANUAL BEFORE INSTALLING AND USING APPLIANCE. FAILURE TO FOLLOW INSTRUCTIONS MAY RESULT IN PROPERTY DAMAGE, BODILY INJURY OR EVEN DEATH.

For more information: www.fornobravo.com
https://www.fornobravo.com/PDF/commercial_install.pdf

Made in the U.S.A. Commercial Wood Fired Pizza Oven



Napoli 140W

Pizza Oven Floor Tile Layout

Architect Drawings



Intertek



Intertek

Revision 01/23/17

Sheet:4 of 4