

Front View

Side Elevation

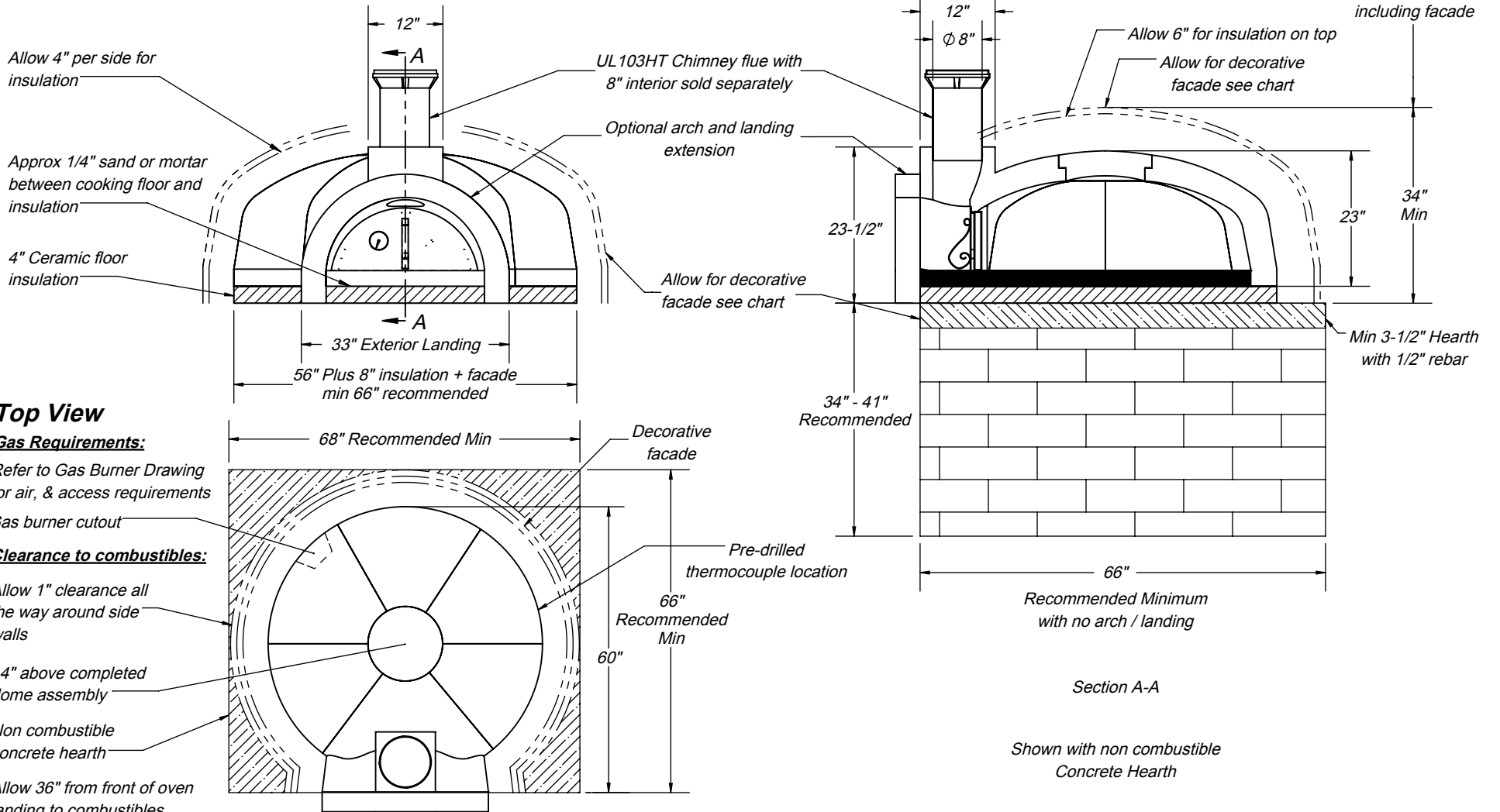

Top View

Gas Requirements:

Refer to Gas Burner Drawing for air, & access requirements

Gas burner cutout

Clearance to combustibles:

Allow 1" clearance all the way around side walls

14" above completed dome assembly

Non combustible concrete hearth

Allow 36" from front of oven landing to combustibles

Specifications:

Wood, liquid gas or propane fuel;

Check local codes for venting requirements.

Product UL listed for UL 103HT direct vent, Grease Duct or Type 1 Hood;

Crate ships 78"W x 82"D x 80"H;

Approx weight 3090 lbs.

Fork truck or dock access required upon delivery



Intertek



Intertek

Decorative Facade Allowances	Depth	Width
Brick Arch	Usually 5"	N/A
Brick Landing	Usually 8"	Preference
Stucco	Approx 1"	Approx 2"
Tile	Approx 1"	Approx 2"
Stone/Brick Veneer	Check Material Spec	Approx 2"
Brick or Masonary non veneer		
UL-2162, UL-737, NSF-4, CAN/CGA-1.8, ANSI-Z83.11 Listed		
For more information: www.fornobravo.com		

Made in the U.S.A. Commercial Gas Fired Pizza Oven



Modena2G 120G

Architect Drawings

Revision 02/04/2016

Sheet 1 of 3

ISO View

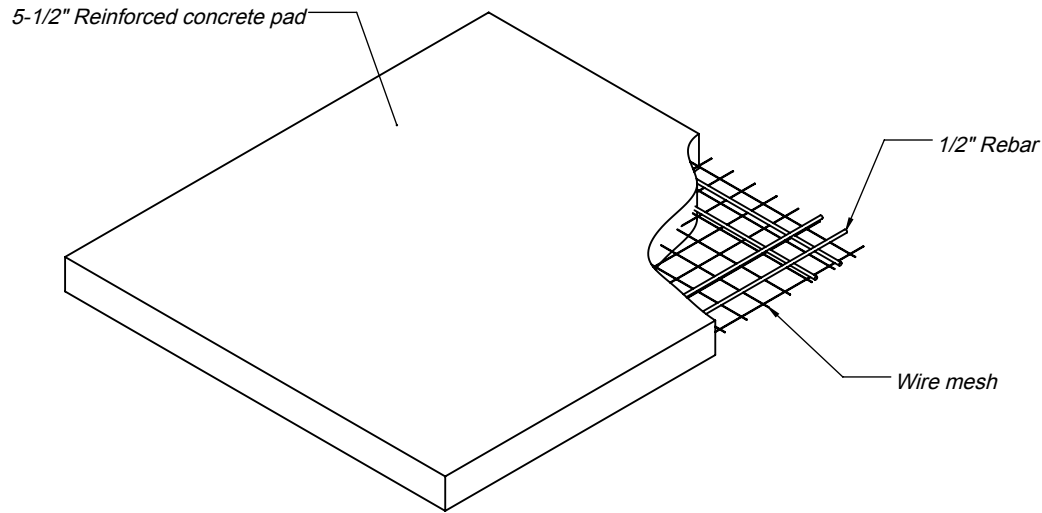

Top View

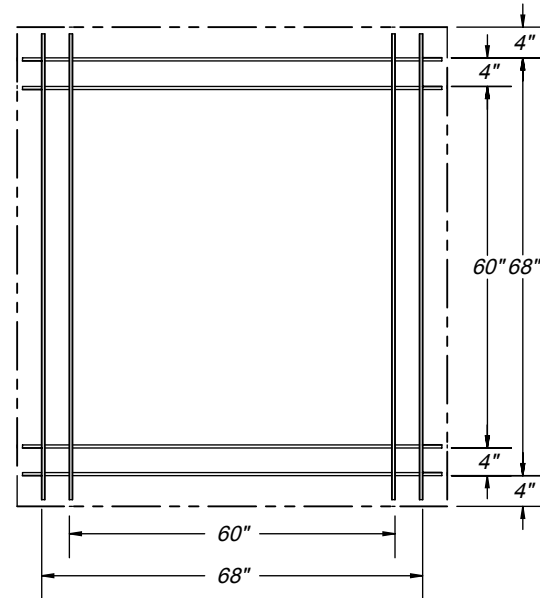

Top View

Modena2G 120G oven stand footprint

Specifications:

Minimum 5-1/2" deep concrete pad;

Reinforced with 1/2" rebar and wire mesh. * wire mesh is not shown in some views for print clarity;

Cut rebar and wire mesh short to conceal inside concrete pad;

Slab dimensions:

Minimum 8" wider than oven stand and hearth;

Minimum 10" deeper than oven stand and hearth;

Finished slab should be 2" to 3" above ground level;

Refer to local building codes for recommendations regarding soil compaction, frost line and other considerations. Depending on local conditions, you may have to excavate down 18" or more of topsoil to reach stable substrate.

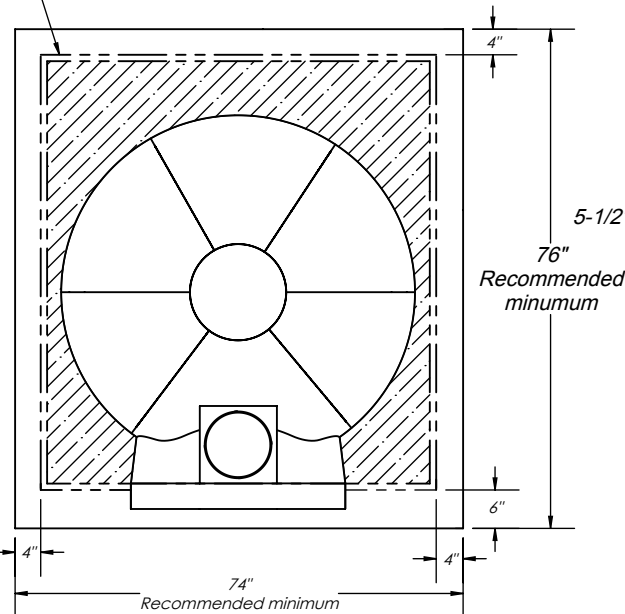

Side Elevation

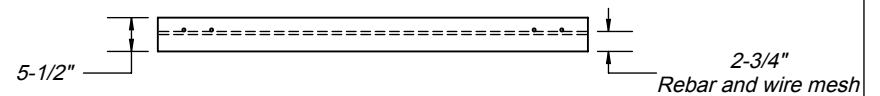

Made in the U.S.A. Commercial Gas Fired Pizza Oven

FORNO BRAVO®
THE WORLD'S FINEST PIZZA OVENS

Mondena2G 120G Foundation
Architect Drawings

Revision 02/04/2016 Sheet 2 of 3



For more information: www.fornobravo.com

ISO View

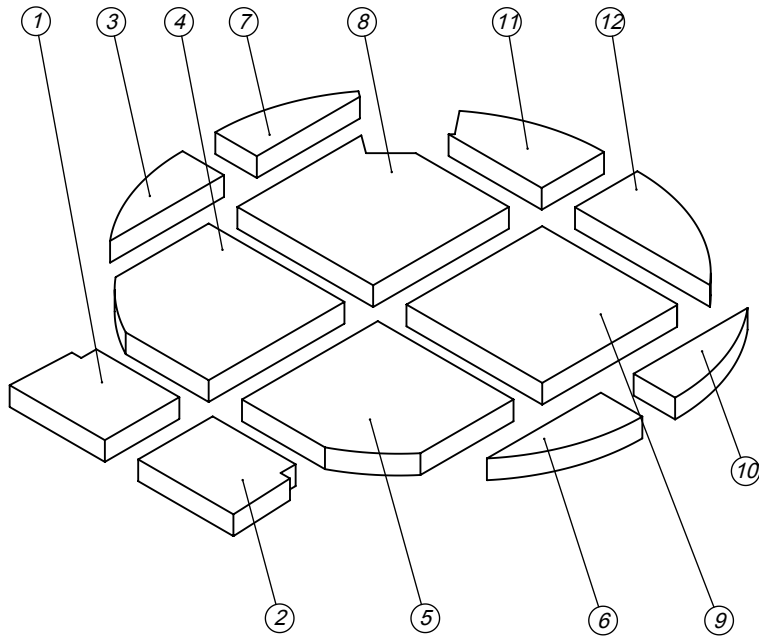

When ordering replacement tiles reference tile number and pizza oven model.

Top View

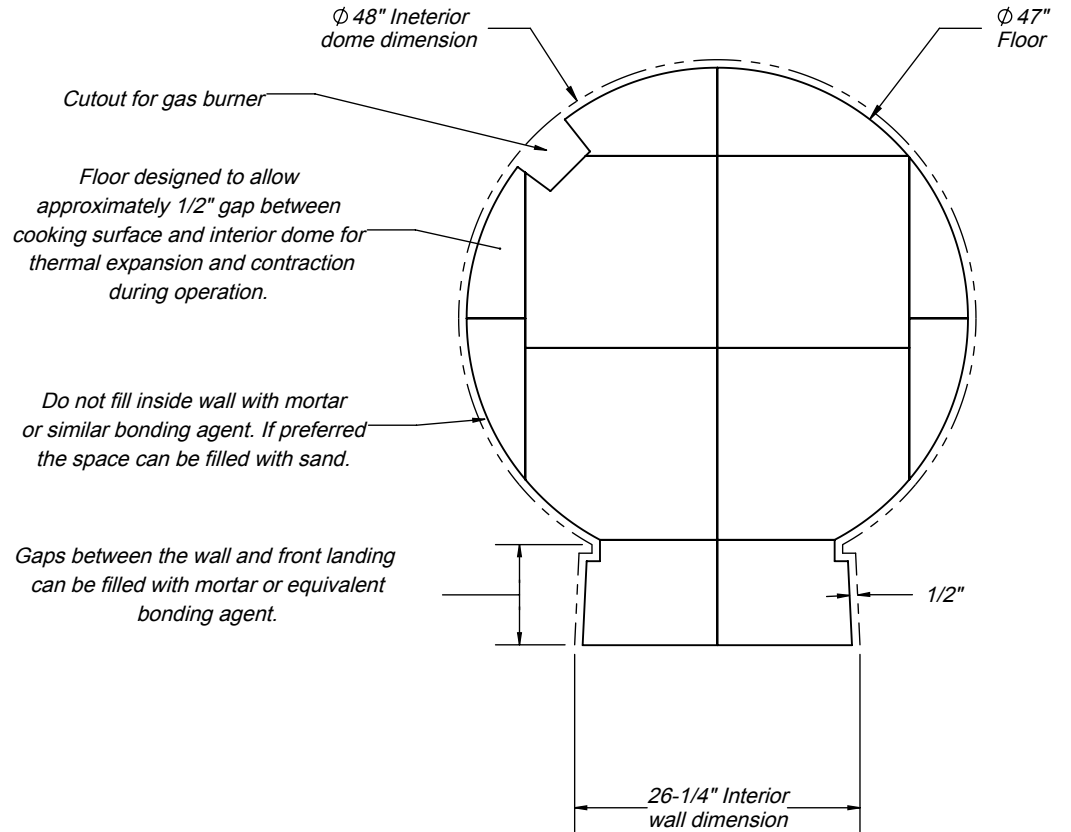

Side Elevation

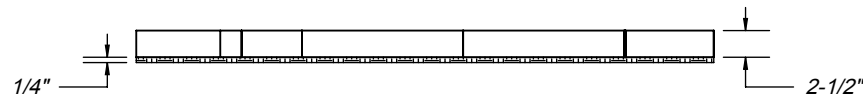

1/4" mortar, sairset, or #60 mesh sand to level pizza oven floor

Specifications:

Pizza oven floor is NSF-4 rated with 2-1/2" thick surface.

Use 1/4" mortar, sairset, or #60 mesh sand to level the pizza oven floor.

No more than 3/8" filler around landing or door may not fit.

For more information: www.fornobravo.com

Made in the U.S.A. Commercial Gas Fired Pizza Oven



Modena2G 120G
Floor Tile Layout



Revision 02/04/2016 Sheet 3 of 3