

Front View

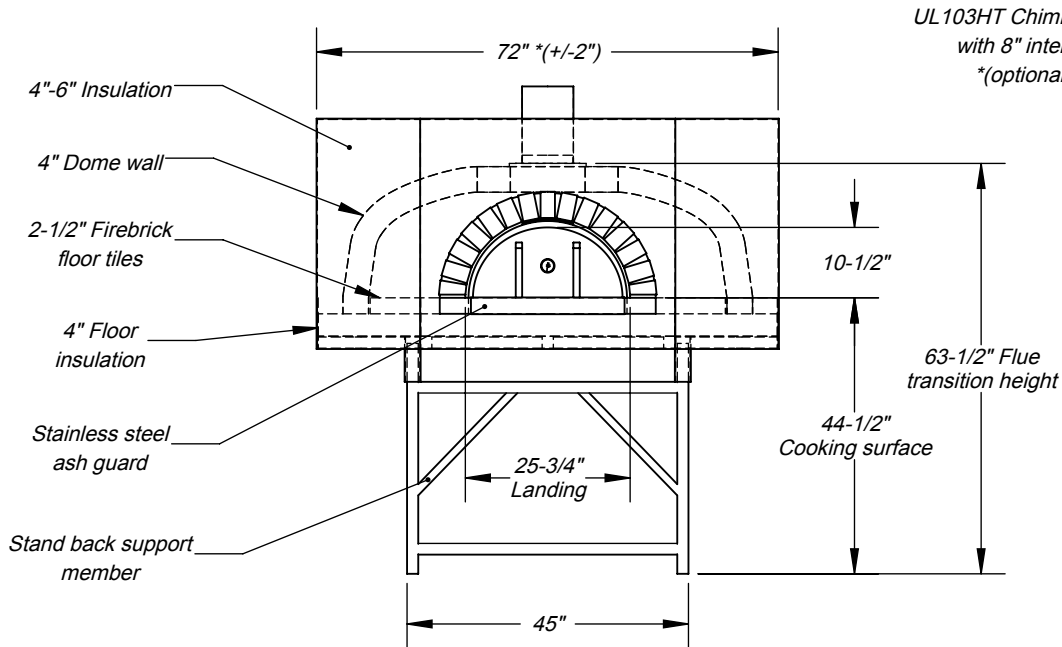

Side Elevation

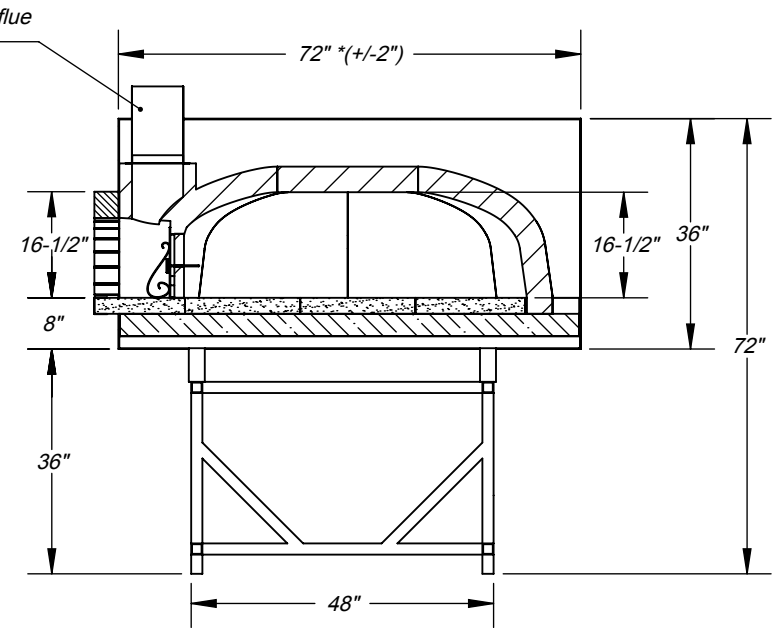

SECTION-A

Shown with non combustible metal hearth

Top View

Gas Requirements:

Refer to Gas Burner Drawing for air, & access requirements

Clearance to combustibles:

- Allow 1" clearance all the way around side walls;
- 14" above completed dome assembly;
- 30" Side clearance from door opening;
- 36" from front of oven landing to combustibles;
- Non combustible metal hearth.

Specifications:

- Wood, liquid gas or propane fuel;
- Check local codes for venting requirements.
- Product UL listed for UL103HT direct vent, Grease Duct or Type 1 Hood;
- Crate ships 84"W x 83"D x 84"H, Oven weight: 4000 lbs..

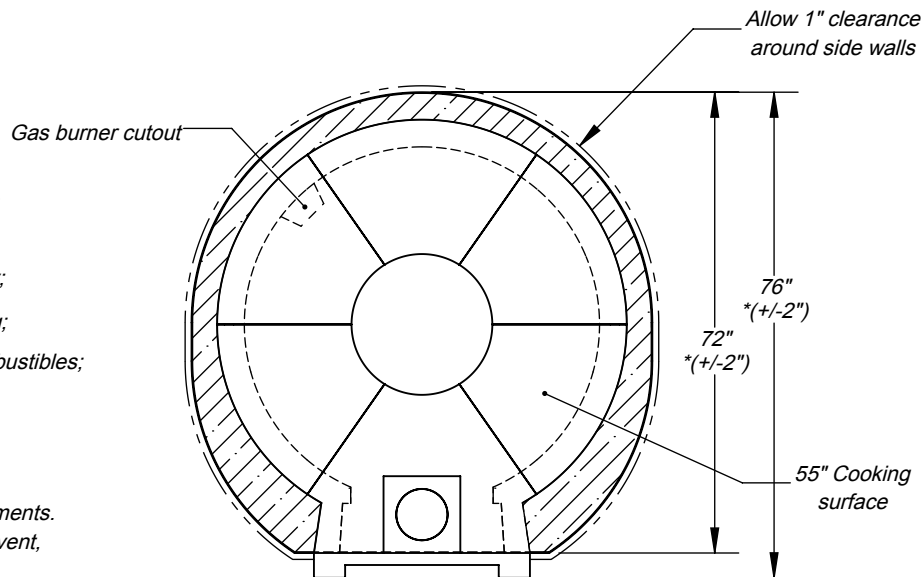

For more information: www.fornobravo.com

Made in the U.S.A. Commercial Gas Fired Pizza Oven

FORNO BRAVO[®]
THE WORLD'S FINEST PIZZA OVENS

Modena2G 140G

Gas Fired Pizza Oven

Architect Drawings SKU: FM2G140-GKD/GFA

Revision 6/16/2016

Sheet: 1 of 3



Intertek



Intertek

ISO View

5-1/2" Reinforced concrete pad

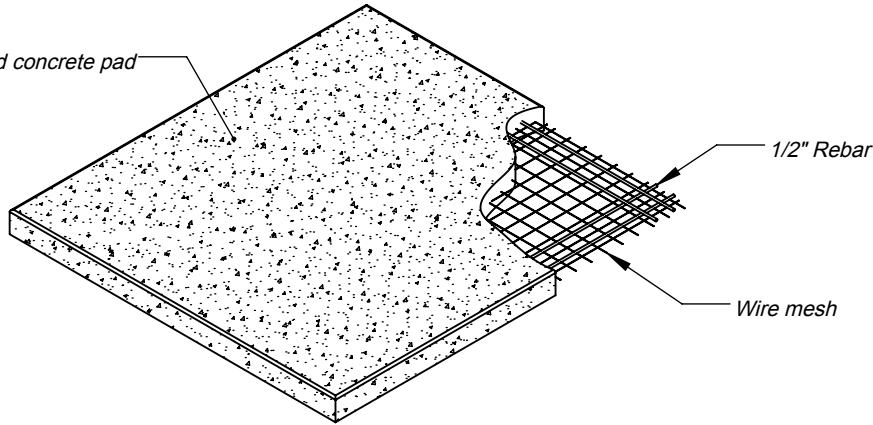

1/2" Rebar

Wire mesh

Top View

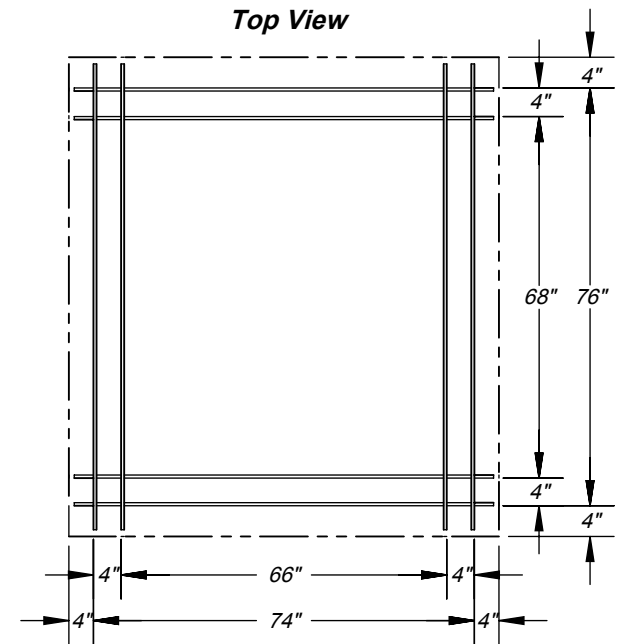

**Modena2G 140G
oven stand footprint**

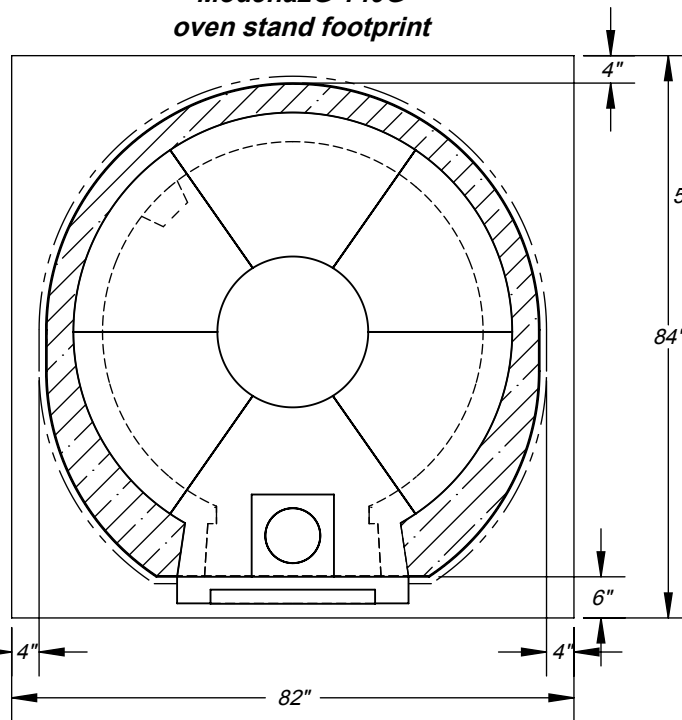

Side Elevation

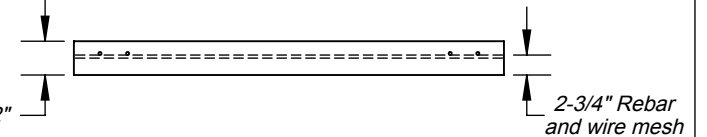

Specifications:

Minimum 5-1/2" deep concrete pad;

Reinforced with 1/2" rebar and wire mesh. * wire mesh is not shown in some views for print clarity;

Cut rebar and wire mesh short to conceal inside concrete pad;

Slab dimensions:

Minimum 8" wider than oven stand and hearth;

Minimum 10" deeper than oven stand and hearth;

Finished slab should be 2" to 3" above ground level;

Refer to local building codes for recommendations regarding soil compaction, frost line and other considerations. Depending on local conditions, you may have to excavate down 18" or more of topsoil to reach stable substrate.

For more information: www.fornobravo.com

Made in the U.S.A. Commercial Gas Fired Pizza Oven

FORNO BRAVO®
THE WORLD'S FINEST PIZZA OVENS

Modena2G 140G
Gas Fired Pizza Oven Pad
Architect Drawings



Revision 6/16/2016

Sheet: 2 of 3

ISO View

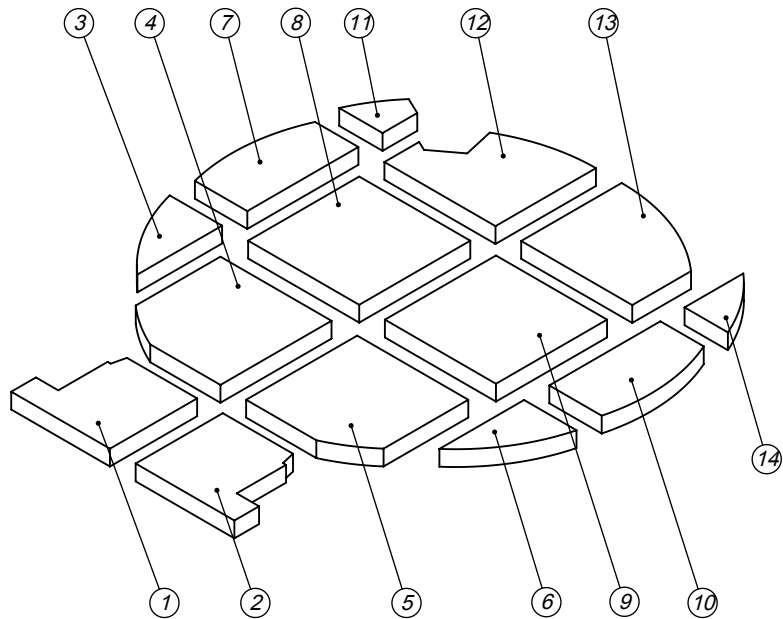

When ordering replacement tiles reference tile number and pizza oven model.

Top View

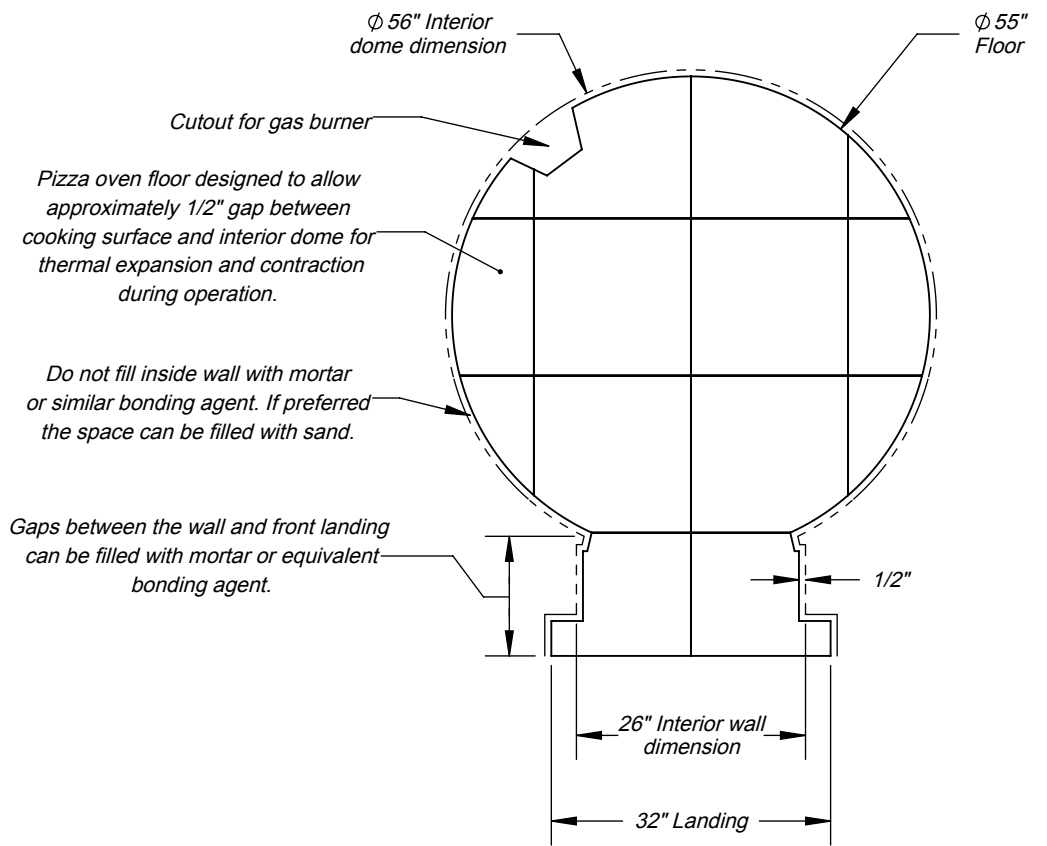

Side Elevation

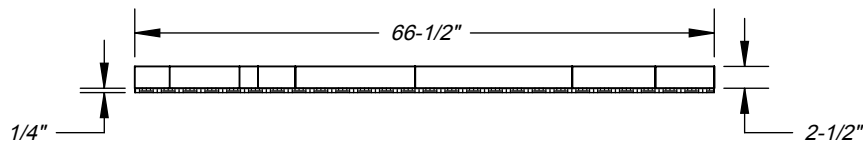

1/4" mortar, sairset, or #60 mesh sand to level pizza oven floor.

Specifications:

Pizza oven floor is NSF-4 rated with 2-1/2" thick surface.

Use 1/4" mortar, sairset, or #60 mesh sand to level the pizza oven floor.

No more than 3/8" filler around landing or door may not fit.

For more information: www.fornobravo.com

Made in the U.S.A. Commercial Gas Fired Pizza Oven

FORNO BRAVO
THE WORLD'S FINEST PIZZA OVENS

Modena2G 140G

Pizza Oven Floor Tile Layout

Architect Drawings SKU: FM0140-GKD/GFA

Revision 6/16/2016

Sheet: 3 of 3

