



# Forno Bravo

Authentic Italian Wood-Fired Ovens

## Specification Sheet

# Modena W Series

### Assembled Wood-Fired Pizza Ovens

#### Wood-Fired Ovens Combine Advanced Technology; Efficient Operation

The Forno Bravo Modena W Series is a line of high-end, UL/NSF-listed pizza ovens designed and produced in Italy for restaurants and pizzerias. The Modena ovens take full advantage of space-age insulators and high-technology refractory materials to provide efficient operation, minimal fuel consumption and optimal pizza making. The Modena ovens are excellent at retaining the high heat that is vital to baking authentic Italian and New York style pizza.

The weight and mass of these pizza ovens are designed for the rigors of high temperature cooking and 24-hour, 365 day per year use. Constructed from a proprietary high alumina, vibrated refractory material, the Modena dome is 3" (sides) – 4" (top) thick. The Modena oven dome is an optimal 16.5" high, and the oven opening is perfectly tuned for cooking performance. The Modena oven floor is 2 3/4" thick, also uses a proprietary high-density refractory, and is cast a single block. With no seams, the Modena oven floor offers the perfect pizza baking environment.

The Modena ovens are capable of quickly reaching and holding the 800°F temperature required to produce hundreds of pizzas per hour. They hold a temperature of 500°F over night, and can be brought back up to cooking temperature in a little at 15 minutes.

By leveraging insulating materials developed for industrial applications (2,000°F+), the Modena ovens remain completely cool on the outside, while cooking at 800°F. The upper oven has up to 8" of ceramic insulation, which is rated to stop 1,000°F for every 4", and the cooking floor is set on 6" of solid-state block insulation.

Restaurant owners and chefs who have experience with a low-end pizza oven, where the oven exterior get hot and the oven quickly loses heat, knows how important this feature is.

The Modena Series ovens come ready to cook, requiring only a chimney. They are available in four sizes.

### Accessories

- Simpson DuraTech chimney
- Infrared thermometer
- Additional oven tools

Tested to UL 737, UL Subject 2162-01, and NSF/ANSI 4-07.



The Modena W Series—advanced technology in a fully assembled oven.

### The Modena W Family

	Cooking Surface (in)	Area (ft <sup>2</sup> )	Pizzas (10")	Pizzas (12")
<b>Modena120</b>	46" x 49"	12.9	7	5
<b>Modena140</b>	55" x 53"	15.5	12	8
<b>Modena160</b>	55" x 61"	18.5	14	10
<b>Modena180</b>	55" x 69"	21.3	16	12



744 Neeson Road, Unit A  
Marina, CA 93933  
(800) 407-5119  
[info@fornobravo.com](mailto:info@fornobravo.com)



# Forno Bravo

Authentic Italian Wood-Fired Ovens

## Specification Sheet

# Modena W Series

### Dimensions

TRADIZIONALE A LEGNA  
DISEGNI E DIMENSIONI

MODELLO	LARG. UTILE <b>L</b>	PROF. UTILE <b>P</b>	LARG. INGOMBRO <b>Li</b>	PROF. INGOMBRO <b>Pi</b>	PESO <b>Kg</b>
120	1200	1200	1600	1550	1100
140	1400	1350	1800	1700	1400
140/160	1400	1550	1800	1950	1600
140/180	1400	1750	1800	2150	1800

### Dimensions and Weight

	Internal	External Width	External Depth	Weight (Lbs.)
Modena120	46.4" x 49.1"	62.9"	60.9"	2,420
Modena140	55.0" x 53.1"	70.7"	66.8"	2,750
Modena160	55.0" x 60.9"	70.7"	76.6"	3,080
Modena180	55.0" x 68.8"	70.7"	84.5"	3,410

### Physical

Height of Cooking Floor: 48"

Dome Height (internal) from Cooking Floor: 16.5"

Oven Opening: 22"W x 10.6"H

Chimney flue: 20cm (7.9")



# Forno Bravo

Authentic Italian Wood-Fired Ovens

## Specification Sheet

### Design

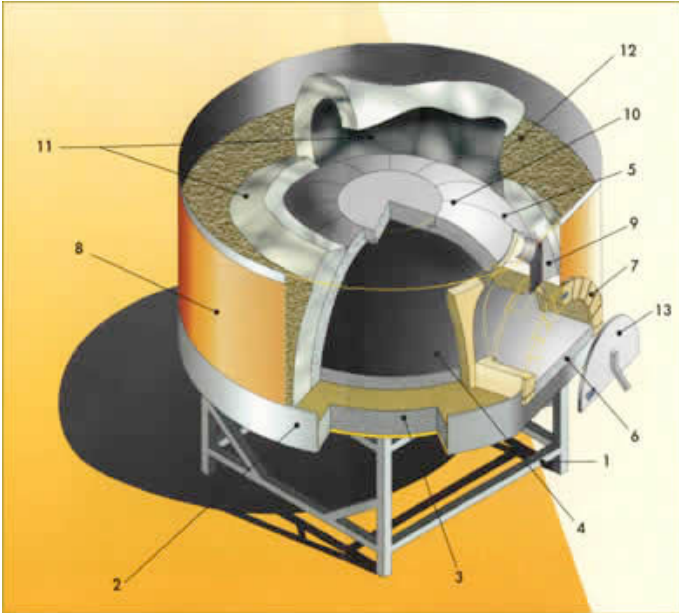

1. Support stand in square tubular steel; stove enamel coating.
2. Steel support platform, reinforced with square tubular steel sections; stove enamel coating.
3. 6" thick under-oven insulation comprised of a double layer of high-efficiency solid-state refractory insulating tiles, fired at 1700°F.
4. Monoblock 2 3/4" cooking floor, made from proprietary high-density, vibrated refractory material.
5. Dome segments 4" top thick, made from proprietary high-density, vibrated refractory material.
6. Oven landing, made from proprietary high-density, vibrated refractory material covered with high-grade stainless steel.
7. Arch, which projects 2" beyond the oven enclosure allowing for custom partition wall enclosure.
8. Steel enclosure panels with red stove enamel coating; durable, washable and non-rusting.
9. Steel vent, with paint finish capable of withstanding high heat.
10. The joints between the dome sections, and between the oven floor and cooktop overlap, and are grouted with refractory plastic mortar capable of withstanding 2500°F.
11. Ceramic fiber dome insulation between 4"-8" thick; capable of withstanding 2500°F.
12. Additional loose insulation.
13. Oven door.