



Modena G Series

Assembled Wood, Gas or Wood/Gas Combo Pizza Ovens

Italian-Made Ovens Offer Advanced Technology; Choice of Fuel

The Forno Bravo Modena G Series is a line of world-class wood, gas or wood/gas combo pizza ovens designed and made in Italy for restaurants, pizzerias and bakeries. The Modena ovens take full advantage of space-age insulators, high-technology refractory materials and advanced electronically controlled burner technology to provide efficient operation, minimal fuel consumption and optimal pizza making. For restaurants looking for an oven that combines the authentic cooking environment of a wood-fired oven, with the convenience and consistency of a one-touch gas oven -- the Forno Bravo Modena G Series makes an excellent choice.

The Forno Bravo Modena G Series wood, gas and gas/wood combination ovens deliver all of the advantages of the traditional Modena wood-fired ovens, with the convenience of gas. The Modena ovens use an electronically controlled, multi-line atmospheric burner, designed specifically for firing Italian dome pizza ovens. The burner was co-developed by the Modena oven producer, and has been available for less than three years.

Oven temperature is controlled electronically, giving the chef easy control over cooking temperatures. The Modena burner works in two modes: a low flame, which is used for maintaining the oven temperature, and a high flame used for quickly bringing the oven to cooking temperature, and for dealing with peak cooking periods. This dual-mode operation delivers economy of operation, combined with optimal performance and cooking.

The Modena burner works on an atmospheric burner principle, where combustion takes place just as it does with wood. There is a natural draw of air through the oven's chimney, and the flame created by the burner is silent, widely diffused and very bright. This natural combustion delivers uniform cooking, high-performance "wood-like" flavors, and low maintenance costs compared with fan-assisted burners.

The Modena G Series oven chamber is identical to the Modena W Series. Constructed from a proprietary high alumina, vibrated refractory material, the Modena dome is 3" (sides) - 4" (top) thick. The Modena oven floor is 2 3/4" thick, uses the same high-density material, and is cast as a single block. With no seams, the Modena oven floor offers the perfect environment for pizza baking.

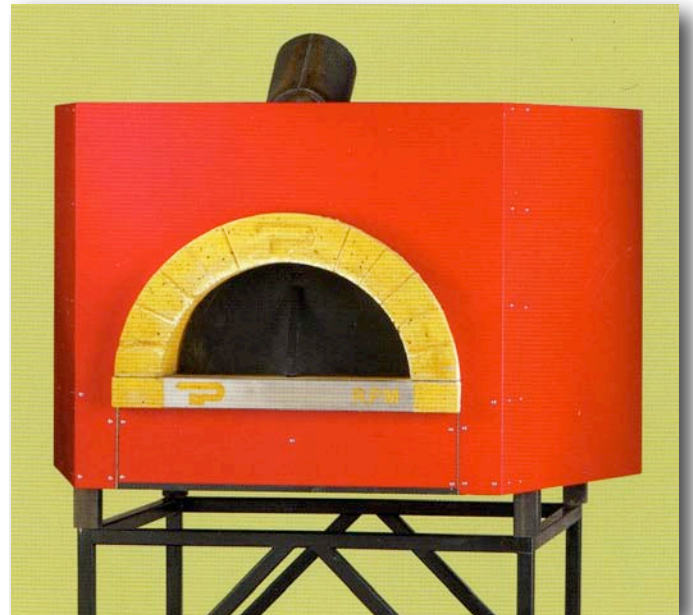

The Modena G—advanced technology in an assembled oven.



The Modena G Family

	Cooking Surface (in)	Area (ft ²)	Pizzas (10")	Pizzas (12")
Modena120	46" x 49"	12.9	7	5
Modena140	55" x 53"	15.5	12	8
Modena160	55" x 61"	18.5	14	10
Modena180	55" x 69"	21.3	16	12

Forno Bravo Modena gas-fired ovens have been tested and approved by Intertek Testing Services, and are ETL Listed to ANSI Z83.11b - 2006, CSA 1.8b-2006, UL Subject 2162, ULC Subject 1482-M1990, and to NSF/ANSI Standard 4 - 2007.





Modena G Series

Dimensions

TRADIZIONALE A LEGNA
DISEGNI E DIMENSIONI

MODELLO	LARG. UTILE L	PROF. UTILE P	LARG. INGOMBRO Li	PROF. INGOMBRO Pi	PESO Kg
120	1200	1200	1600	1550	1100
140	1400	1350	1800	1700	1400
140/160	1400	1550	1800	1950	1600
140/180	1400	1750	1800	2150	1800

Dimensions and Weight

	Internal	External Width	External Depth	Weight (Lbs.)
Modena120	46.4" x 49.1"	62.9"	60.9"	2,420
Modena140	55.0" x 53.1"	70.7"	66.8"	2,750
Modena160	55.0" x 60.9"	70.7"	76.6"	3,080
Modena180	55.0" x 68.8"	70.7"	84.5"	3,410

Physical

Height of Cooking Floor: 48"

Dome Height (internal) from Cooking Floor: 16.5"

Oven Opening: 22"W x 10.6"H

Base Insulation: 5.9"

Dome Insulation: 3.9"

Chimney flue: 20cm (7.9")

Burner Specifications

3/4" NPT gas connection

Natural gas or LP (please specific prior to ordering)

Natural Gas: 5 to 8 inches WC

Propane (LP): 12 to 15 inches WC

The gas supply must be capable of providing at least 125,000BTU at listed pressures. Gas connection: 1/2"

Electrical: 110V, 100 watt

Design

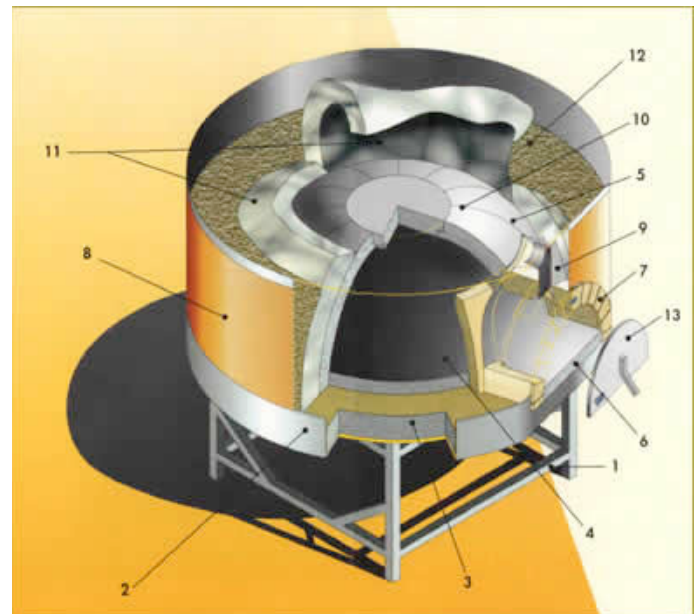

1. Support stand in square tubular steel; stove enamel coating.
2. Steel support platform, reinforced with square tubular steel sections; stove enamel coating.
3. 6" thick under-oven insulation comprised of a double layer of high-efficiency solid-state refractory insulating tiles, fired at 1700°F.
4. Monoblock 2 3/4" cooking floor, made from proprietary high-density, vibrated refractory material.
5. Dome segments between 3" sides and 4" top thick, made from proprietary high-density, vibrated refractory material.
6. Oven landing, made from proprietary high-density, vibrated refractory material covered with high-grade stainless steel.
7. Arch, which projects 2" beyond the oven enclosure allowing for custom partition wall enclosure.
8. Steel enclosure panels with red stove enamel coating; durable, washable and non-rusting.
9. Steel vent, with paint finish capable of withstanding high heat.
10. The joints between the dome sections, and between the oven floor and cooktop overlap, and are grouted with refractory plastic mortar capable of withstanding 2500°F.
11. Ceramic fiber dome insulation between 4"-8" thick; capable of withstanding 2500°F.
12. Additional loose insulation.
13. Oven door.