



The Ristorante Range of Commercial Wood-Fired Pizza Ovens

The Forno Bravo Ristorante range of pizza ovens are designed exclusively for restaurants, pizzerias and bakeries. These pizza ovens are made by Italy's largest and finest producer of wood-fired ovens and have a track record of proven performance and reliability. There are thousands of these ovens still cooking after more than 10 years of service like they were new.

The weight and thermal mass of these pizza ovens are designed for the rigors of high temperature, 24-hour/365 days use. Constructed from 75 mm (3") thick tempered, high alumina refractory material, the Ristorante ovens quickly reach and hold the 400 °C temperature required to produce up to 240 pizzas per hour.



Because the Ristorante pizza ovens heat up quickly and are efficient with wood fuel, they reduce operational costs. The sophisticated thermal design of these ovens enables them to maintain high overnight temperatures, thus reducing the start up time for the next day, and reducing wood consumption. In fact, the Ristorante pizza ovens reduce wood costs by 30% compared with other traditional ovens.

The oven's innovative cast iron doorframe maximizes space for placing pizza and food in the oven, while retaining maximum heat inside the oven. The Ristorante Series is available in six large sizes designed for restaurant, delicatessen and small bakery use.

Ristorante Oven	110	120	130	145	160	185
Cooking area (ft ²)	10¾	13½	14½	19¼	22½	30
Cooking area m ²	1	1.25	1.35	1.8	2.1	2.8
Heat up time (min)	50	50	55	60	60	60
Pizzas 250 mm (10")	6	7	8	10	12	15
Bread (kilos)	12	14	16	20	24	32

The ovens come with a choice of two terracotta style arches and landings pictured below. The arch incorporates the flue manifold and flue connection.

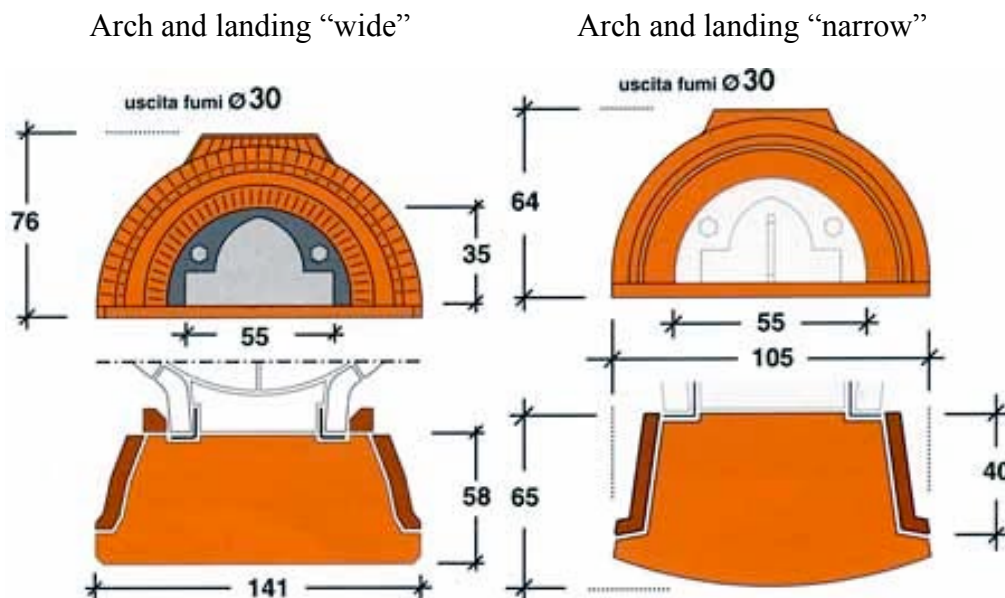

Supplied with each oven, and included in the price, are the terracotta style arch and landing with integrated flue manifold (suitable for connection to modular stainless steel chimney systems), thermometer, cast iron oven opening, steel door, 25 mm (1") ceramic insulating blanket and a three-piece oven tool set. The Forno Bravo Ristorante range of ovens can be installed using either a Forno Bravo metal stand, or can be built on a custom block / brick base constructed at the restaurant or bakery site.



Ristorante 110

The Forno Bravo Ristorante 110 consists of a four-piece oven dome and a five-piece cooking floor

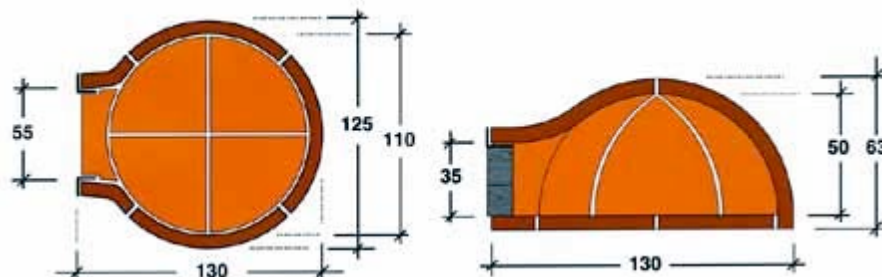

110	External (W x D x H)	Internal	Oven Opening (W x H)
Dimensions	125 (49) x 130 (54) x 63 (25) cm (")	110 (43¼) cm (")	55 (21½) x 35 (13¾) cm (")
Cost	£3,265.00 plus £185.00 delivery		Total £3,450.00

Ristorante 120

The Forno Bravo 120 oven consists of a five-piece dome and a six-piece cooking floor

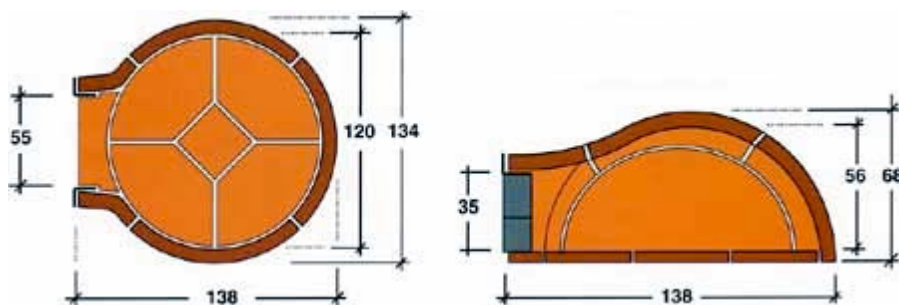

120	External (W x D x H)	Internal	Oven Opening (W x H)
Dimensions	134 (52¾) x 138 (54¾) x 68 (26¾) cm (")	120 (47¼) cm (")	55 (21½) x 35 (13¾) cm (")
Cost	£3,659.00 plus £185.00 delivery		Total £3,844.00



Ristorante 130

The Forno Bravo Ristorante 130 oven has a five-piece oven dome and a six-piece cooking floor

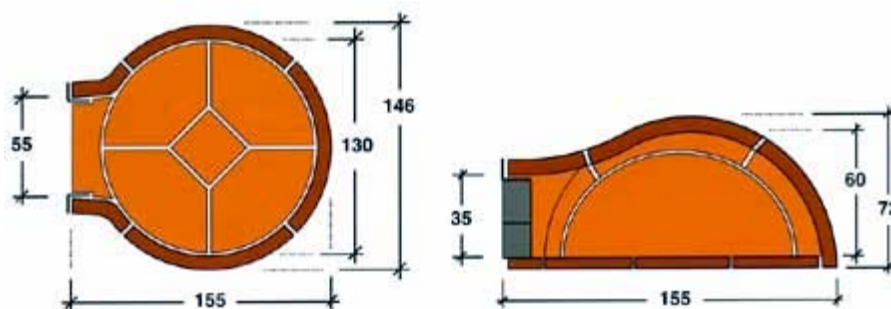

130	External (W x D x H)	Internal	Oven Opening (W x H)
Dimensions	146 (57½) x 155 (61) x 72 (28¼) cm (")	130 (51¼) cm (")	55 (21½) x 35 (13¾) cm (")
Cost	£4,055.00 plus £185.00 delivery		Total £4,240.00

Ristorante 145

The Forno Bravo Ristorante 145 oven has a seven-piece oven dome and a nine-piece cooking floor

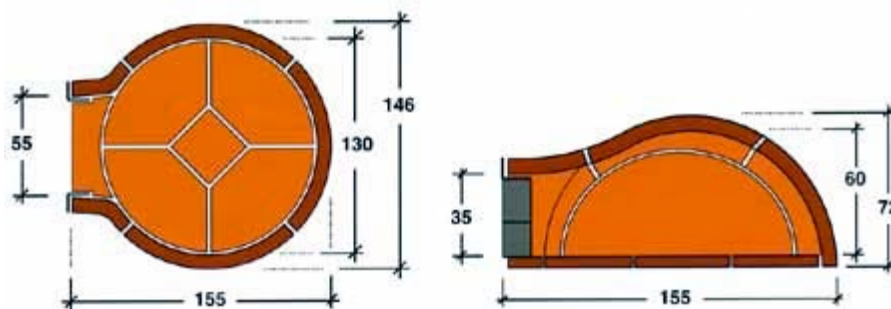

145	External (W x D x H)	Internal	Oven Opening (W x H)
Dimensions	160 (63) x 173 (68) x 80 (31½) cm (")	145 (57) cm (")	55 (21½) x 35 (13¾) cm (")
Cost	£4,449.00 plus £185.00 delivery		Total £4,634.00



Ristorante 160

The 160 oven consists of a nine-piece oven dome and a nine-piece cooking floor.

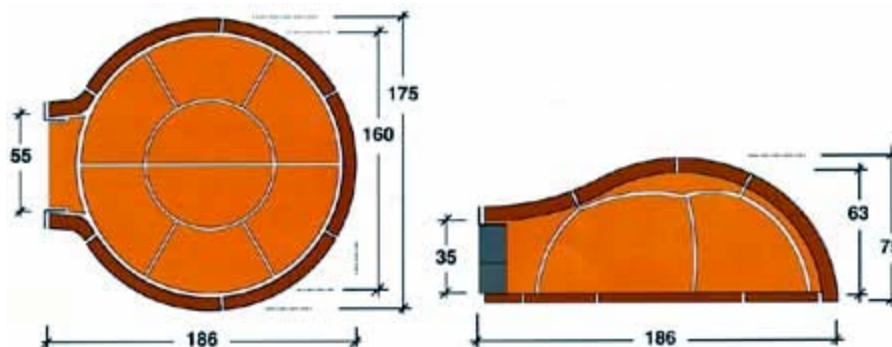

160	External (W x D x H)	Internal	Oven Opening (W x H)
Dimensions	175 (69) x 186 (73¼) x 75 (29½) cm (")	160 (63) cm (")	55 (21½) x 35 (13¾) cm (")
Cost	£4,912.00 plus £185.00 delivery		Total £5,097.00

Ristorante 185

The Forno Bravo 185 oven consists of a ten-piece oven dome and an eleven-piece cooking floor

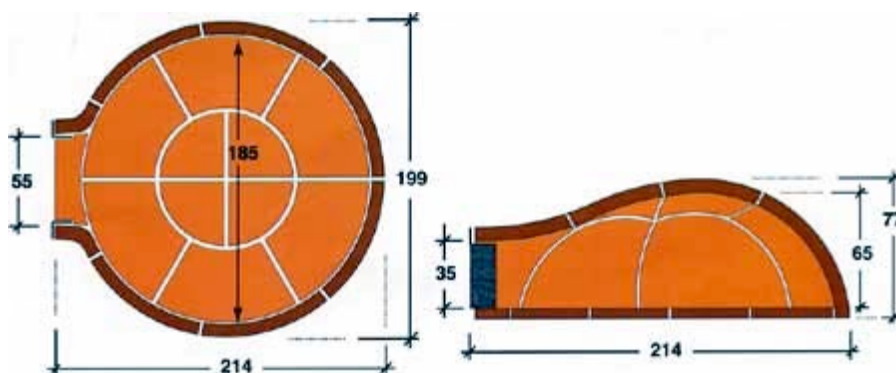

185	External (W x D x H)	Internal	Oven Opening (W x H)
Dimensions	199 (78¼) x 214 (84¼) x 77 (30¾) cm (")	185 (72¾) cm (")	55 (21½) x 35 (13¾) cm (")
Cost	£5,308.00 plus £185.00 delivery		Total £5,493.00



Footprint Required for Ristorante Ovens

For the Ristorante ovens to operate at the correct temperature and burn the fuel efficiently the ovens need to be correctly insulated. The table below gives the minimum footprint required to install each oven.

Minimum footprint required for ovens with both the narrow and wide arch		
Oven	Width cm (")	Depth cm (")
Ristorante 110	155 (61)	185 (73)
Ristorante 120	164 (64½)	193 (76)
Ristorante 130	176 (69½)	210 (82½)
Ristorante 145	190 (75)	228 (89¾)
Ristorante 160	205 (80¾)	241 (95)
Ristorante 185	229 (90½)	269 (106)

Note: the footprint dimensions allow for the ovens ceramic insulating blanket and vermiculite insulation

Forno Bravo Prefabricated Oven Stand

The Forno Bravo prefabricated stand allows for a much quicker site installation. Our engineers can arrive on site, install the metal stand, oven base insulation, cooking floor, oven dome and dome insulation in one operation.



Installed Forno Bravo prefabricated stand and insulated oven base for a Ristorante 110 oven

Once the oven installation is complete, local craftsmen can cover / hide the insulation enclosure with materials of your choice.

The Forno Bravo prefabricated stand and insulation enclosure can be modified to suite any installation situation, i.e. oven arch within the restaurant and the insulation enclosure behind a wall, corner installation etc.



Complete Forno Bravo Ristorante 110 oven with narrow arch, stand and insulation enclosure with log box under the oven

Costs for Forno Bravo prefabricated stand and insulated oven base	
Oven	
Ristorante 110	£350.00
Ristorante 120	£380.00
Ristorante 130	£410.00
Ristorante 145	£520.00
Ristorante 160	£620.00
Ristorante 185	£790.00
Note: the above prices include the galvanised steel insulation enclosure and log box.	

Our installation cost is dependant on the site location and access, please email or call with your requirements and we will quote you direct