



Casa Series

Precast Refractory Pizza Ovens

Professional Wood-Fired Cooking at Home

The Forno Bravo Casa Series is a family of UL737, UL2162 and NSF listed modular pizza ovens designed for indoor and outdoor residential use. Fabricated using the same high-tech refractory material as our commercial ovens, the Casa ovens offer professional-grade wood-fired cooking at home. The ovens are available in five sizes, ranging from a 31.4" round to a 43.2" x 62.9" oval.

Hand-crafted by Italy's largest producer of wood-fired ovens, the Casa ovens are perfect for the enthusiast home chef, as well as building contractors looking for outstanding performance in an oven that can be easily incorporated into any indoor or outdoor kitchen design.

Unlike old-fashioned "clay" ovens, the Casa Series brings the advantages of high tech oven technology to the homeowner. The thermal mass and design of the Casa ovens is optimized for home use. The ovens heat up quickly, in less than an hour, and maintain their cooking temperature for hours – perfect for weekend pizza parties, bread baking and Thanksgiving roast.

The Casa Series stores heat well and provides an optimal environment for both authentic two-minute, 750°F+ Pizza Napoletana, and artisan hearth breads.

The ovens incorporate an enclosed refractory vent landing, vent and chimney adapter, making it easy to attach either a steel or terracotta chimney.

The Casa ovens can be easily installed either on a site-built concrete block stand and hearth, or on a Forno Bravo Cucina metal oven stand. We can help with all of your installation material needs, including high-tech insulation and UL103 listed chimney.

Each oven includes the dome and cooking floor, steel door, vent and chimney adapter, 50 sq. ft insulating blanket and three-piece Italian-made oven tool set.

Installation Accessories

- RefMix refractory mortar
- FB Board under-oven insulating panels
- Simpson DuraTech UL103 chimney
- Decorative brick arch

Cooking Accessories

- Infrared thermometer
- Tuscan grill
- Additional oven tools
- Terracotta bakeware



Forno Bravo Casa—the perfect wood-fired oven engine.

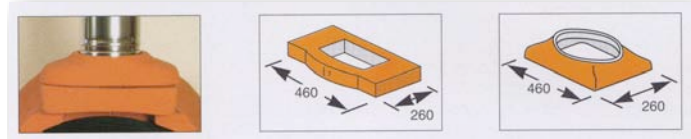

True refractory vent for performance and durability

The Casa Family

	Cooking Surface (in)	Area (m ²)	Heat up	Pizzas (10")	Bread (lb.)
Casa80	31.4"	0.50	40	1-2	12
Casa90	35.4"	0.72	45	2-3	17
Casa100	39.3"	0.80	50	3-4	22
Casa110	43.2"	0.95	50	4-5	26
Casa160	43.2" x 62.9"	1.25	50	5-6	31

The Casa ovens can also be delivered as a fully assembled Toscana oven. Just set it in place and start cooking.



Forno Bravo

Authentic Italian Wood-Fired Ovens

Forno Bravo, LLC
399 Business Park Court, #104
Windsor, CA 95492
(800) 407-5119
www.fornobravo.com

The Forno Bravo Showroom is open by appointment.





Casa Series

Each Oven Includes

Oven Dome, Floor and Door

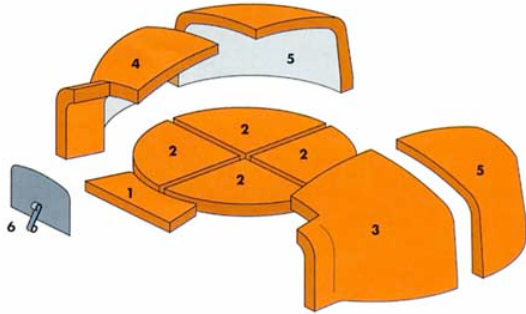

Refractory Vent

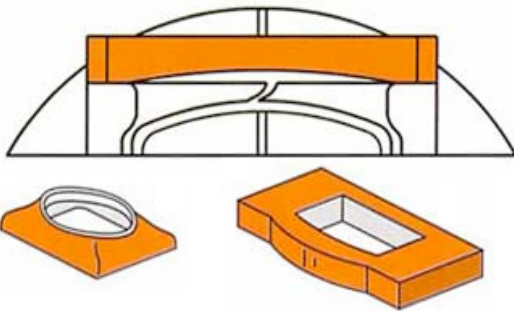

Round chimney adapter

Refractory Vent

Tool Set



FB Blanket Insulating Blanket



Options (purchased separately)

DuraVent Chimney



RefMix Refractory Mortar



FB Board Under Oven Insulation





Casa Series

Oven Specifications

Casa80

Our smallest oven, the Casa80 heats up quickly and can cook two small, or one medium pizza a time. It is the right oven for tight spaces.

External

38.9"D x 35.4"W x 19.3"H

Internal

31.4" round cooking surface (80 cm)

Oven Opening

17.3"W x 9.8"H

Weight

450 pounds, including vent and chimney manifold

Two-piece dome; two-piece floor

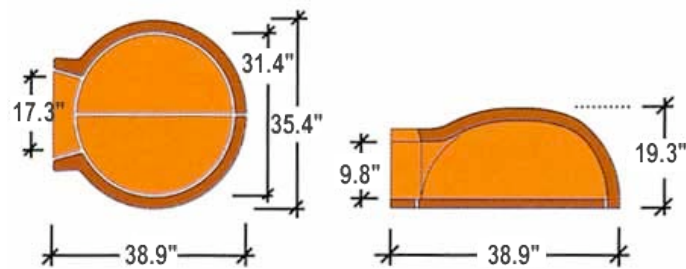

Casa90

The Casa90 is a very popular oven size, cooking three personal pizzas at a time, or roasts and vegetables.

External

43.6"D x 40.1"W x 20.8"H

Internal

35.3" round cooking surface (90cm)

Oven Opening

18.5"W x 9.8"H

Weight

650 pounds, including vent and chimney manifold

Two-piece dome; four-piece floor

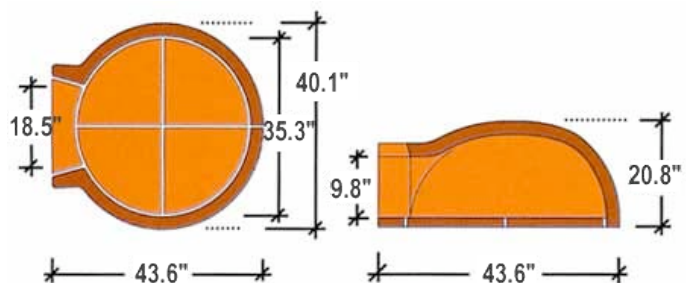

Casa100

Popular with the cooking enthusiast, the Casa100 provides more space for multiple roasting pans, along with room for more pizza and bread.

External

48.7"D x 44.0"W x 19.7"H

Internal

39.3" round cooking surface (100cm)

Oven Opening

18.9"W x 11.8"H

Weight

950 pounds, including vent and chimney manifold

Four-piece dome; four-piece floor

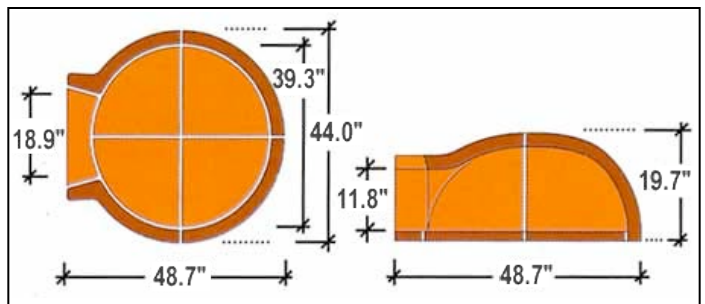

Casa110

Perfect for the serious chef, the Casa110 can be the center of attention for larger parties and family events.

External

51.1"D x 48.0"W x 19.7"H

Internal

43.2" round cooking surface (110 cm)

Oven Opening

18.9"W x 11.8"H

Weight

1150 pounds, including vent and chimney manifold

Four-piece dome; four-piece floor

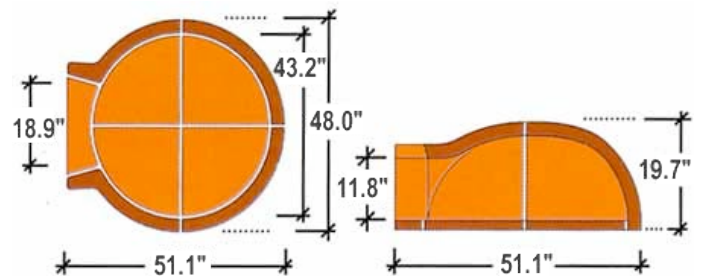



Casa Series

Oven Specifications

Casa160

The ultimate party machine, the Casa160 could also serve in catering and restaurant applications.

External

70.7"D x 48.0"W x 19.7"H

Internal

43.2" round cooking surface (110 cm)

Oven Opening

18.9"W x 11.8"H

Weight

1350 pounds, including vent and chimney manifold

Six-piece dome; six-piece floor

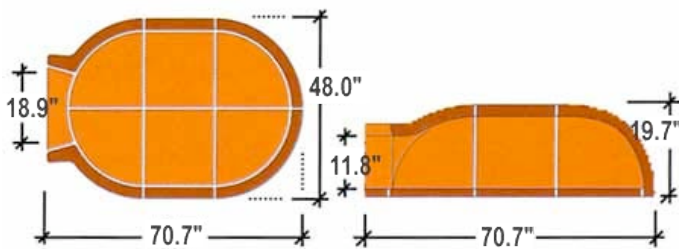

Stand Dimensions

The Casa oven can be assembled on a concrete block stand, or on a Forno Bravo Cucina metal stand. The dimensions of the stand depend on a number of factors, including the size of your oven, the thickness of your upper enclosure walls, the insulating schedule you are using and the depth of your oven landing. Here is a guideline:

	Oven Exterior	Hearth Width	Hearth Depth
Casa80	35.4"W x 38.9"D"	50"	58"
Casa90	40.1"W x 43.6"D"	54"	62"
Casa100	44.0"W x 48.7"D"	58"	66"
Casa110	47.9"W x 51.1"D"	62"	70"
Casa160	47.9"W x 70.7"D"	62"	89"

These dimensions are based on 1" woven ceramic insulation, 4" vermiculite insulation, 2" upper walls and a 12" oven landing. Adjust your dimensions accordingly.

