



## Casa80 Refractory Wood Fired Oven

The Forno Bravo Casa80 is our smallest, most cost-effective modular oven for the house and garden. Fabricated using the same high-tech refractory material as our commercial ovens, the Casa family of ovens offers a truly world-class wood-fired cooking experience.

The Casa80 features a round 31.4" cooking surface, and is capable of cooking one or two 10" pizzas or 12 loaves of bread, or holding multiple roasting pans. The oven produces perfect Italian 3-minute pizzas, making it the right size oven for family entertaining. And because the Casa80 has a small footprint, it is the perfect choice for tight spaces.

Built by Italy's largest producer of wood-fired ovens, the Casa family is the right choice for homeowners and professional builders looking for outstanding performance in an oven that can be easily incorporated into a custom indoor or outdoor kitchen design.

The thermal mass of the Casa Series ovens is optimized for home use. The Casa80 heats up and is ready to cook in an outstanding 40 minutes, and maintains its cooking temperature for hours -- perfect for weekend entertaining, hearth bread and Thanksgiving roast.

The Casa80 oven features a 2" refractory cooking surface, also constructed from the same high tech refractory material as our commercial ovens, providing the world's best (some say only) environment for true Italian pizza.

The Casa80 incorporates an enclosed refractory vent landing, and concrete vent and chimney manifold, making it easy to attach either a modular steel chimney system, or a terra cotta or concrete flue liner. Because the vent is made from the same heat-resistant material as the rest of the oven, it will give you years of worry-free operation.

The Casa ovens can be finished in virtually any exterior style, including an Igloo, gabled house, wall oven and barrel vault, and can be easily installed on a site-built concrete block stand. The oven opening can be finished with an optional three-piece brick arch for a traditional Italian look, or with any custom finish material.

The oven includes a ceramic insulating blanket and three-piece oven tool set.



Casa80 oven chamber – the perfect wood-fired oven engine

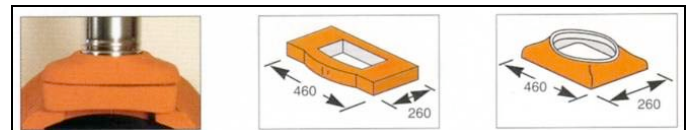

Casa refractory vent and chimney manifold

### The Casa Family

Oven	Cooking Surface (in)	Cooking Area (m <sup>2</sup> )	Heat up (min)	Pizzas (10")	Bread (lbs)
<b>Casa80</b>	31.4"	.50	40	2	12
<b>Casa90</b>	35.5"	.72	45	3	17
<b>Casa100</b>	39.3"	.80	50	4	22
<b>Casa110</b>	43.2"	.95	50	5	26

### Optional Accessories

Decorative brick arch  
Refrax refractory mortar  
Infrared thermometer

Forno Bravo, LLC  
PO Box 160  
Healdsburg, CA 95448  
(707) 836-0105  
info@fornobravo.com



# Casa80 Oven Specifications

### Physical

#### External

35.37"W x 38.91 "L x 19.26"H

#### Internal

31.44" round cooking surface

#### Oven Opening

17.29"W x 9.83"H

#### Weight

450 pounds, including vent and chimney manifold

#### Includes

- Two piece dome
- Two piece cooking surface
- Landing
- Refractory concrete vent
- Chimney manifold
- Metal door
- 1" ceramic insulating blanket
- Oven tool set

### Installation

#### Design Options

- Igloo
- Gabled house
- Wall oven
- Barrel vault

#### Foundation (recommended)

59"W x 69"D

Note: this allows for 4" on the sides and back for the stand for finish material, and 6" on the front for finish material for finish material and floor for wood storage

#### Block stand and hearth (recommended)

51"W x 59"D

Note: these dimensions allow for 1" refractory coating, 1" insulating blanket, 4" vermiculite, 1" stucco and 1" reveal. Depth allows 12" for arch and landing. You should adjust your final stand size to your exact insulation and arch/landing depth.

### Dimensions

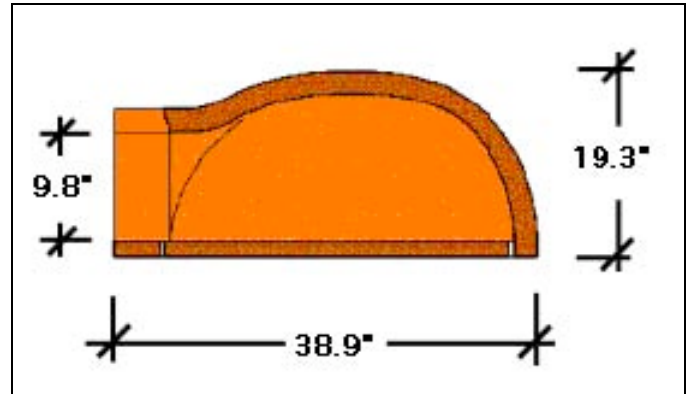

Side view

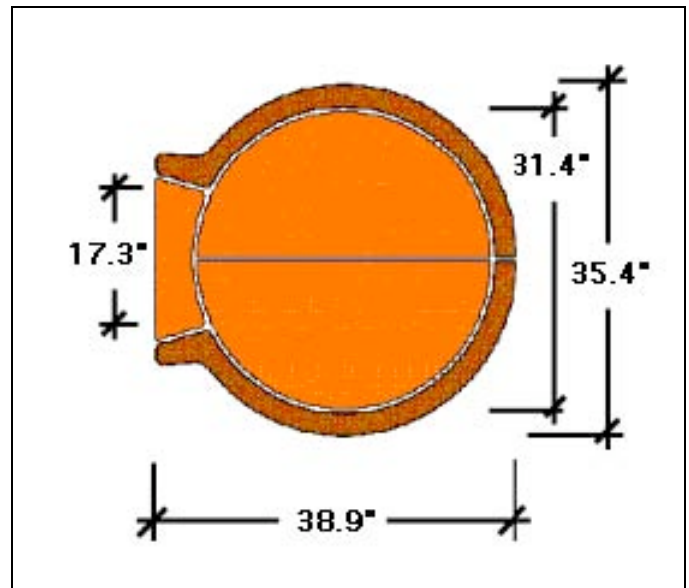

Top View

Forno Bravo, LLC  
 PO Box 160  
 Healdsburg, CA 95448  
 (707) 836-0105  
 info@fornobravo.com